

**KeeVac**  
Industries  
866-789-9440  
www.keevac.com

# Slide In Vacuum Tank Catalog

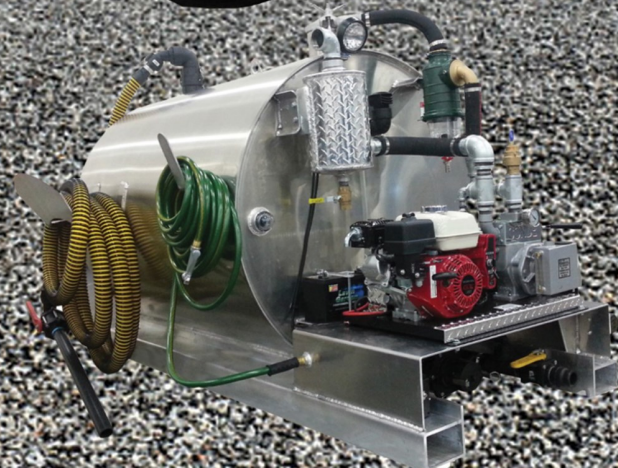

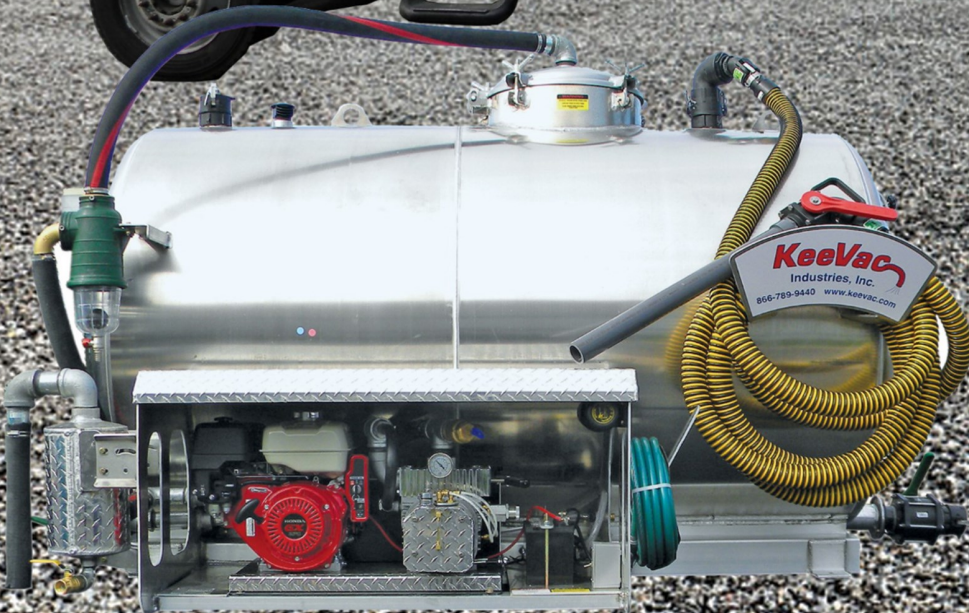



## FD Series Slide-In Vacuum Tank Standard Features

5454-H32 Marine grade mill finish aluminum

2 configurations to choose from:

“RE” – Pump located on rear (end) side of tank

“SE” – Pump located on side of tank and set up for conventional mount

20" X 2" Hose connection NVE low profile primary with stainless steel ball and cage

3" Discharge with 3" full port poly ball valve, male camlock and dust cap

3" Top nipple with 2" adapter for Tigertail Suction hose

(2) 5" Sight eyes in rear Head

Half-moon style hose hook suction hose

Hose hook for wash down hose (on two compartment models only)

(1) Work light

Full length fork lift pockets

Masport HXL2V (76 CFM) vacuum/pressure pump, Direct Drive

12v wash down pump, 6.0 GPM, 45 PSI

2" MZ plastic secondary

2" Diamond plate aluminum oil trap

2" Bucket fill with 2" straight male camlock fitting

2" x 30' Tigertail suction hose with 2" full port 90 degree valve with 30" schedule 80 PVC wand

½" x 50' wash down hose with spray nozzle

12v battery

All units come with a kit that contains: (1) 2" 90 male camlock for option to replace straight camlock on bucket fill, (20') of red 6-gauge battery cable for option to wire battery on unit to truck battery, (1) 2" female camlock to garden hose adapter for fresh water fill through bucket fill

### Notes:

Any "FD" single compartment model deletes the following items: Wash down hose and spray nozzle, 12v wash down pump, bucket fill, garden hose hook, sight tube, vent, strainer, fresh plumbing. Some models will have deletion of internal bulk head, other models will have bulk head replaced with baffle.

ALL FREIGHT QUOTES WILL BE GOOD FOR 24 HOURS. AFTER 24 HOURS FREIGHT WILL BE CHARGED BASED ON NEW QUOTE PRICE PROVIDED BY SHIPPING VENDOR. ALL CUSTOMERS ARE ALLOWED TO SET UP FREIGHT WITH THEIR OWN CARRIERS IF THEY CHOOSE TO.



## FD Series—Rear Engine

| Model        | Capacity | Description  |
|--------------|----------|--|
| FD300-1C-RE  | 300      | 300 Gallon, single comp, standard features         |
| FD300-2C-RE  | 300      | 200 Waste x 100 fresh, two comp, standard features |
| FD435-1C-RE  | 435      | 435 Gallon, single comp, standard features         |
| FD435-2C-RE  | 435      | 300 Waste x 135 fresh, two comp, standard features |
| FD600-1C-RE  | 600      | 600 Gallon, single comp, standard features         |
| FD600-2C-RE  | 600      | 400 Waste x 200 fresh, two comp, standard features |
| FD800-1C-RE  | 800      | 800 Gallon, single comp, standard features         |
| FD800-2C-RE  | 800      | 550 Waste x 250 fresh, two comp, standard features |
| FD950-1C-RE  | 950      | 950 Gallon, single comp, standard features         |
| FD950-2C-RE  | 950      | 650 Waste x 300 fresh, two comp, standard features |
| FD1200-1C-RE | 1200     | 1200 Gallon, single comp, standard features        |
| FD1200-2C-RE | 1200     | 900 Waste x 300 fresh, two comp, standard features |

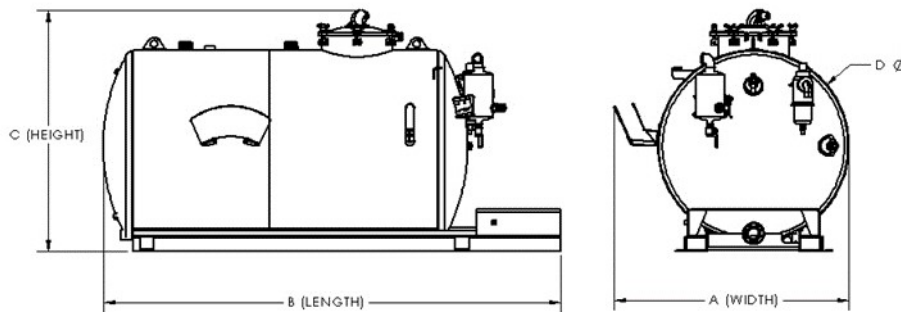

| Capacity    | A    |          | B    |          | C    |          | D     | Weight (HXL2V) |          |
|-------------|------|----------|------|----------|------|----------|-------|----------------|----------|
|             | unit | shipping | unit | shipping | unit | shipping | Diam. | Unit           | shipping |
| 300 Gallon  | 55   | 59       | 87   | 91       | 566  | 60       | 42    | 800            | 900      |
| 450 Gallon  | 60   | 64       | 91   | 95       | 63   | 67       | 48    | 1100           | 1200     |
| 600 Gallon  | 68   | 72       | 93   | 97       | 69   | 73       | 54    | 1150           | 1250     |
| 800 Gallon  | 68   | 72       | 116  | 120      | 69   | 73       | 54    | 1200           | 1300     |
| 1000 Gallon | 68   | 72       | 131  | 135      | 69   | 73       | 54    | 1400           | 1500     |
| 1200 Gallon | 68   | 72       | 141  | 144      | 69   | 73       | 54    | 1600           | 1700     |
| 1500 Gallon | 68   | 72       | 156  | 160      | 69   | 73       | 54    | 1800           | 1900     |



## FD Series—Side Engine, Conventional Mount

| Model        | Capacity | Description   |
|--------------|----------|---|
| FD600-1C-SE  | 600      | 600 Gallon, single comp, standard features          |
| FD600-2C-SE  | 600      | 400 Waste x 200 fresh, two comp, standard features  |
| FD800-1C-SE  | 800      | 800 Gallon, single comp, standard features          |
| FD800-2C-SE  | 800      | 550 Waste x 250 fresh, two comp, standard features  |
| FD950-1C-SE  | 950      | 950 Gallon, single comp, standard features          |
| FD950-2C-SE  | 950      | 650 Waste x 300 fresh, two comp, standard features  |
| FD1200-1C-SE | 1200     | 1200 Gallon, single comp, Standard features         |
| FD1200-2C-SE | 1200     | 900 Waste x 300 fresh, two comp, standard features  |
| FD1500-1C-SE | 1500     | 1500 Gallon, Single comp, standard features         |
| FD1500-2C-SE | 1500     | 1100 Waste x 400 fresh, two comp, standard features |

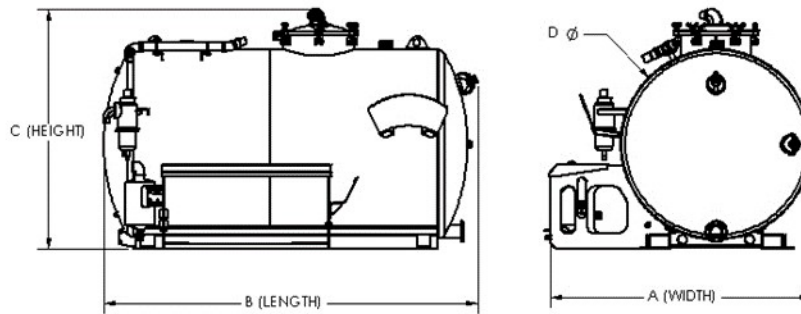

| Capacity    | A    |          | B    |          | C    |          | D<br>Diam. | Weight (HXL2V) lbs. |          |
|-------------|------|----------|------|----------|------|----------|------------|---------------------|----------|
|             | unit | shipping | unit | shipping | unit | shipping |            | unit                | shipping |
| 600 Gallon  | 69   | 73       | 91   | 95       | 63   | 67       | 48         | 1150                | 1250     |
| 800 Gallon  | 75   | 79       | 93   | 97       | 69   | 73       | 54         | 1200                | 1300     |
| 950 Gallon  | 75   | 79       | 108  | 112      | 69   | 73       | 54         | 1400                | 1500     |
| 1200 Gallon | 75   | 79       | 134  | 138      | 69   | 73       | 54         | 1600                | 1700     |
| 1500 Gallon | 75   | 79       | 162  | 166      | 69   | 73       | 54         | 1800                | 1900     |



# **KeeVac**

**Industries**

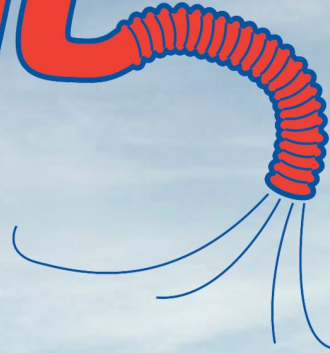

[www.keevac.com](http://www.keevac.com) | 866-789-9440