



324 Leaside Avenue
Stoney Creek, ON Canada L8E 2N7
Tel: 905-662-6552 / TF: 1-800-663-9003
Fax: 905-662-5412

www.fruitlandmanufacturing.com

FRUITLAND VACUUM PUMP

Operation and Maintenance

RCF 172, 344 Models



Attention:
Read owner's manual fully before operating pump.
Failure to do so can result in severe pump damage and may void warranty.

CONTENT

Fruitland Vacuum Pump Designations	3
Fruitland Pump Mounts Designation.....	4
Pump Operation & Maintenance.....	5
Installation & Adjustments.....	6
Lubrication & Approved Oils.....	9
Oil Pump Adjustment	11
Vacuum Pump Flushing Procedure	12
Vacuum Pump & System Maintenance	14
Vacuum Pump Drive Systems	16
Fruitland Right Angle Gearbox	20
Fruitland Hydraulic Motor	21
Drive Shaft Installation & Phasing	23
Vane Wear Measurement	24
Trouble Shooting Pump & System Malfunctions	27
Vacuum Actuated Cooling System (VACS)	28
RCF 172 Pump Parts & Dimensions	29
RCF 172 Exploded View	30
RCF 172 Detailed Item Numbers	31
ELIM A-SMF172RL Exploded View	34
ELIM A-SMF172RL Detailed Item Numbers	35
ELIM G172L Exploded View	36
ELIM G172L Detailed Item Numbers	37
ELIM H-SMF172RL Exploded View	39
ELIM H-SMF172RL Detailed Item Numbers	40
RCF 344 Pump Parts & Dimensions	41
RCF 344 Exploded View	42
RCF 344 Detailed Item Numbers	43
ELIM A-SMF344RL Exploded & Dimensional Views	46
ELIM A-SMF344RL Detailed Item Numbers	49
ELIM G-SMF344L Exploded & Dimensional Views	51
ELIM G-SMF344L Detailed Item Numbers	52
ELIM H-SMF344RL Exploded & Dimensional Views	55
ELIM H-SMF344RL Detailed Item Numbers	57
Truck Mounting Instructions For Eliminator Systems With Angle Drive	59
Warranty	60
Serial Number	62

FRUITLAND VACUUM PUMP DESIGNATIONS

RCF Model Nomenclature:

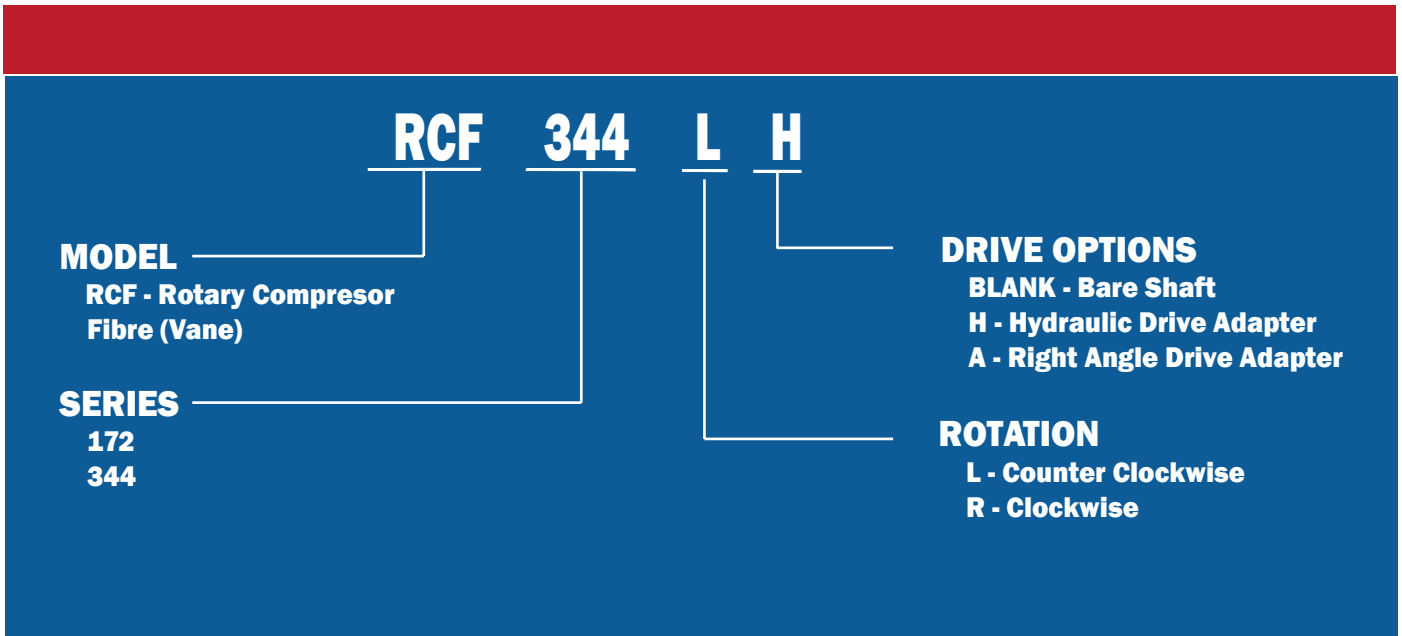

Ordering Information:

1. Choose Rotation L or R
2. Choose drive option A or H; OR specify belt drive or pulley

Sample Model Code:

RCF344LUH – Rotary Compressor Fiber Vane Pump model 344 series pump with left hand rotation, four-way valve on top and Hydraulic Drive Adapter.

Model 172



Model 344



FRUITLAND PUMP MOUNTS DESIGNATIONS

ELIM Model Nomenclature:

ELIM TBM-SM500LUFXXX

MODEL

ELIM - Eliminator Series

DRIVE OPTIONS

A - Right Angle
 H - Hydraulic
 D - Diesel Engine
 DH - Diesel Engine - HATZ
 E - Electric Drive
 G - Gas Engine
 J - Pressure Washer Pump
 SB - Side Mount Belt (Kit Only)
 TB - Top Frame Mount Belt (Kit Only)
 TBM - Top Frame Mount Belt (Mack)

COMPONENTS

BLANK - Bracket Only
 S - Secondary
 M - Muffler
 M02 - Round Muffler
 SMF - Secondary Muffler Filter Combo
 (172, 250, 344)

PUMP ARRANGEMENT

L - Left Rotation
 R - Right Rotation
 BLANK - No Vacuum Pump
 LUF - CCW, Top Valve, Filter
 LUFH - CCW, Top Valve, Filter, Hyd
 LSFH - CCW, Side Valve, Filter, Hyd

PUMP OPTIONS

BLANK - No Vacuum Pump
 172 - RCF 172 Pump
 250 - RCF 250 Pump
 344 - RCF 344 Pump
 370 - RCF 370 Pump
 500 - RCF 500 Pump
 870 - RCF 870 Pump
 1200 - RCF 1200 Pump

SPECIAL INSTRUCTIONS

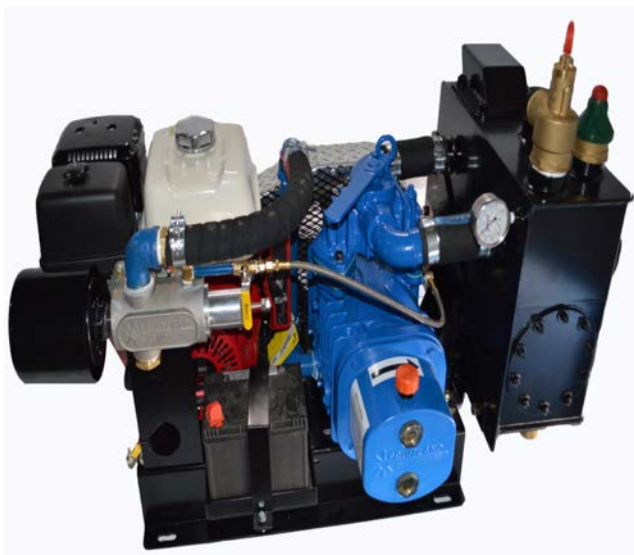

The Fruitland® Eliminator Series offers the reliability of the Fruitland® Pump, combined with the ease and simplicity of our "Ready2Rig" Pump Mounts. We offer several design options including heavy duty pump stands, secondary shutoffs, mufflers, angle drive, hydraulic drive and belt drive options. Tailor your Eliminator package to your specific needs and enjoy effortless installation combined with the power and durability of Fruitland®.

PUMP OPERATION & MAINTENANCE





WARNING

Read Operations and Maintenance Manual fully before operating the vacuum pump. Failure to do so may result in severe system damage that may cause severe injury, death, and void the pumps warranty.

INSTALLATION & ADJUSTMENTS

Lifting

Lift pump by eye bolts, if provided, or with slings around body of pump close to legs.

Mounting

Secure pump unit to flat sturdy surface with four bolts, washers and lock washers, through holes in the base of the pump legs.

RPM

Fruitland Vacuum Pumps should never exceed the RPM stated on the plate tag (pump damage is possible). Pump may be run 20% slower than the stated RPM on the tag if required.

*Vacuum-Pressure Gauge:

Required to SAFELY operate and monitor the systems performance. Locate this gauge at an Operational location and or after the primary and secondary shut-offs/scrubbers to prevent failure due to foreign material.

*Pressure & Vacuum Relief Valves:

Regulates the operating Pressure & Vacuum levels within the system. There should be a minimum of two of each relief valve within your system. One set of reliefs upon the tank and one set of reliefs near the pump. All Relief Valves are rated per CFM (cubic feet per minute) and must be sized accordingly to your vacuum pump system and as recommended by the vacuum tank manufacturer.



WARNING

Always verify the correct Relief valve settings with the tank manufacturer. Failure to do so may cause catastrophic failure, injury and/or death.

Vacuum & Pressure Relief Adjustment



Fruitland Pressure Relief - PART # PRV2

Release the anti-rotation screw (1) - turn the upper ring (3) - rotate clockwise - CW - to increase pressure OR rotate counter clockwise - CCW - to decrease pressure in vessel.

When the desired pressure in the vessel is achieved, slightly turn the upper ring (3) until the flattened spot upon the wheel's shaft is achieved. Tighten the anti-rotation screw and the pressure relief is now set.

Fruitland suggests this procedure and verification of your pressure reliefs operation within your system are re-checked and or set during your routine maintenance schedule for the tank and truck.

*Fruitland Vacuum Relief - PART # VB

Remove the setting screw cover (1) - insert a flat tip screwdriver into the incision and pry off the cover carefully. Loosen the stop set nut (3) - hold firm the vacuum relief bell (2) - Turn the bell clockwise - CW - to increase pressure and turn the bell counter clockwise - CCW - to reduce pressure in the vessel.

During this adjustment it is not necessary to hold the set nut stem (3) with a screwdriver.

When desired pressure in the vessel is achieved, tighten the stop set nut (3) - hold firm the vacuum relief bell (2). Install the setting screw cover (1) - and the vacuum relief is now set.

To eliminate tampering with the adjusted setting of the vacuum relief - insert wire through the screw cover (1) and then into bell (2) and connect wire with a permanent seal.

Fruitland suggests this procedure and verification of your pressure reliefs operation within your system to be re-checked and or re-set during your routine maintenance schedule for the tank and truck.

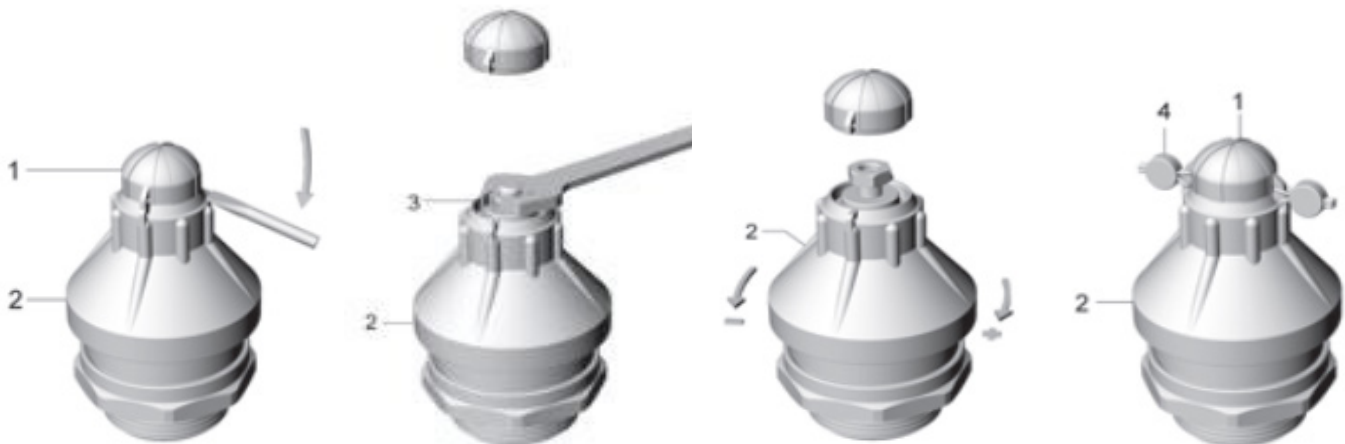

In addition to the incorporation of vacuum & pressure reliefs the outside of these valves, vacuum pump housing, pump shroud and pumps cooling fan blades should, at all times be kept clean of all debris to allow proper pump & system cooling.

Failure to allow air to be conveyed through your vacuum pump & system may result in severe system damage that may cause severe injury, death, and void the pumps warranty.



ATTENTION

All Fruitland Vacuum pumps should never run for a prolonged period of time without air passing through the pump & system itself. Incorporating vacuum & pressure relief valves is highly recommended

SERVICE NOTE

USE AUTHENTIC FRUITLAND PARTS ONLY!

If you have any questions, or require further information on installing, operating and or the maintenance of your vacuum pump contact:

1-800-663-9003 - info@fruitland-mfg.com - sales@fruitland-mfg.com

* If you require these components, please contact your supplier or Fruitland Manufacturing (They may not be included in the pump or package you acquired)

LUBRICATION & APPROVED OILS

Lubrication: If the suction temperature is >50°F (summer conditions), a SAE-40 non detergent motor oil or an ISO 150 compressor oil can be used. If the suction temperature is <50°F (Winter Conditions) a SAE-30 non detergent motor oil or an ISO 100 compressor oil is recommended. **Always check oil level before starting unit.**



NEVER ALLOW OIL RESERVOIR TO GET LOW!!!

Vacuum pumps dispose of and or consume oil during operation and do not have a return within the system. **All vacuum pumps will have an oil sight glass, tube or dipstick. If a remote reservoir is used, verify that this reservoir has oil. Always use the manufacturer's recommended oil. The oil level needs to be checked on a routine basis during the vacuum pumps operation.**

All Pump Models

Oil Tank - Important! During routine cleaning & freezing weather, drain possible condensation build-up in the bottom of the oil tank. Water can enter oil tank and be ingested into the oil pump, this could cause the oil pump to freeze and damage the internal gears of the oil pump. If you suspect water is present within the oil tank reservoir, drain and clean the oil tank with diesel fuel.

Oil Consumption - approximate:

	RCF172	RCF344
1 Litre	18 hr	8 hr
1 Imp. Gal.	82 hr	36 hr
1 US Gal.	68 hr	30 hr

Oils Approved for use in Fruitland Vacuum Pumps

OIL TYPE	WINTER WEIGHT	SUMMER WEIGHT
FRUITLAND® GREEN™ OIL (100% Biodegradable)	SAME	SAME
¹ SHELL TURBO T OIL	32	68 or 100
¹ ISO COMPRESSOR OIL	100	150
MONOLEC COMPRESSOR OIL*	SAME	SAME
MOBIL SHC 525 (Synthesized Hydrocarbon)	SAME	SAME
¹ MOBIL DTE	LIGHT OR	HEAVY MEDIUM
ANDEROL 497	MEDIUM SAME	SAME
¹ CHEVRON GST	32	68
¹ PENNZOIL PENNZBELL TO OIL	32 or 46	68
¹ TEXACO REGAL R & O OIL	32	68
¹ SAE NON DETERGENT OIL	10 or 20	30 or 40
SHELL ROTELLA 15W-40 MOTOR OIL	SAME	SAME

These oils have been approved for use in Fruitland Vacuum Pumps. Use of these oils will maintain the vacuum pump warranty as well as extend the life of the vacuum pump and ensure proper performance and lubrication.

When operated properly, Fruitland vacuum pumps will run cooler, use less oil and provide much longer service than any other rotary vane vacuum pump.

*Monolec Compressor Oil is colored red and should not be confused with transmission fluid.

¹ Recommended for the best performance and lubrication at all temperature levels.

Oils & Fluids That Are Not Approved For Use In Fruitland Vacuum Pumps

OIL TYPE	OIL TYPE	OIL TYPE
BRAKE FLUID	HYDRAULIC FLUID	TRANSMISSION FLUID
DEF FLUID	POWER STEERING	USED OIL VEGETABLE
GEAR OIL	FLUID SCENTED OIL	USED OIL



WARNING

Always check oil level before starting vacuum pump, Fill if necessary. Operating your Fruitland vacuum pump with the incorrect oil can result in misuse of this product that may result in severe injury, death, severe system damage, and or void the pump's warranty.

OIL PUMP ADJUSTMENT

Fruitland vacuum pump's oil pump comes pre-adjusted from the factory and rarely requires any adjustment during their life time. However if a need arise, the following procedure should be followed to adjust the oil flow rate.

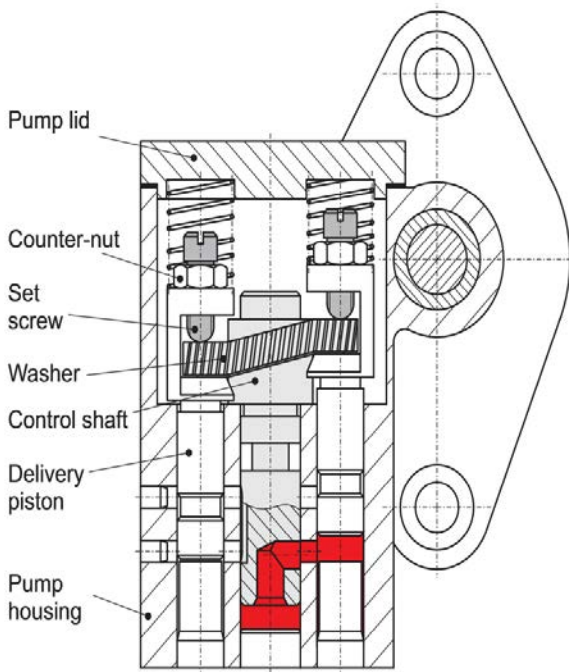

Oil Rate Adjustment:

The oil rate can be adjusted in two ways:

- 1- Using a feeler gauge of thickness "A" to adjust the gap.
- 2- Turning the adjusting screw by specified turns from fully closed position.

Use the following table for reference.

Pump Model	A, inch	Screw Turns (approx)	L/hour	Hour/L
RCF172	0.095"	3-1/8	0.083	18
RCF344	0.05"	1-5/8	0.230	8

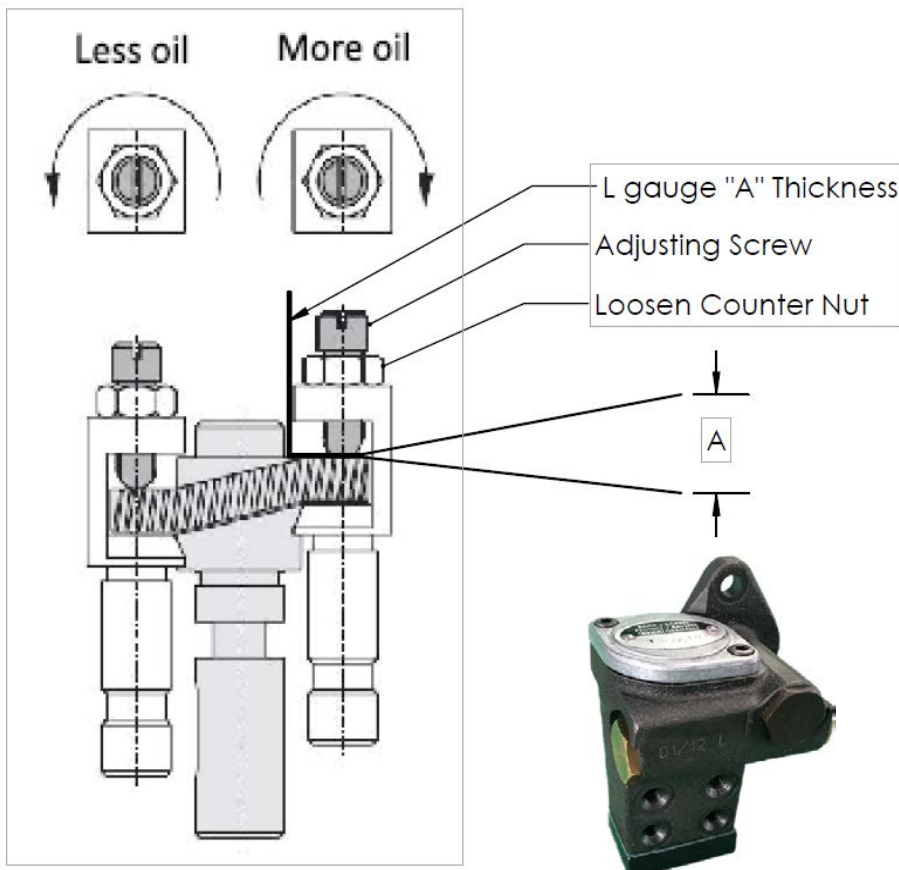

Note:

- Due to space limitations, a custom designed small L shaped feeler gauge of "A" thickness can be used to adjust the gap.
- One full turn of adjusting screw is 0.030" (0.75mm) and one counter clockwise turn reduces the oil output by 1/3 of the total oil delivery volume.



VACUUM PUMP FLUSHING PROCEDURE

Flush the Pump

During your routine scheduled service of your tank truck and vacuum system perform the manufactures suggested Pump Flushing Procedure. This will remove the caked oil and carbon build-up from within the vacuum pump and the oil catch muffler system expelling this carbon & debris build-up out of the oil catch muffler's drain valve. Flushing the system on a routine basis will also help in reducing smoke due to the fact of eliminating varnish and or carbon build-up from within the oil catch muffler and vacuum pump.

Pump Flushing Procedure

1. Stop the pump and remove ¼ " npt plug located on the pump diverter valve
2. Connect a brass fitting, rubber hose, ball valve and flushing fluid bottle to this port
3. Run the Pump, switch to vacuum and slowly open the ball valve
4. Pass approximately 2 to 3 liters of the flushing fluid through the pump while restricting/controlling the flushing fluid flow through the ball valve.
5. Close the ball valve and run the pump for an additional minute to remove all the flushing fluid from the pump.
6. Drain the oil catch muffler or oil separator
7. If you remove the Pump flushing fittings from the pump, make sure to re-install the ¼ " NPT plug back into the port.
8. Resume pumping operation

For ease of operation, Fruitland recommends installing our Pump Flushing Kit (Part #FK500) to assist in this procedure.



WARNING

Flushing your Fruitland vacuum pump with the incorrect fluid type can result in misuse of this product that may result in severe injury, death, severe system damage, and or void the pump's warranty.

If you have any questions or require further information on installing, operating, and or flushing your vacuum pump contact:

1-800-663-9003 - info@fruitland-mfg.com - sales@fruitland-mfg.com

Fruitland Vacuum Pump Flushing Kit

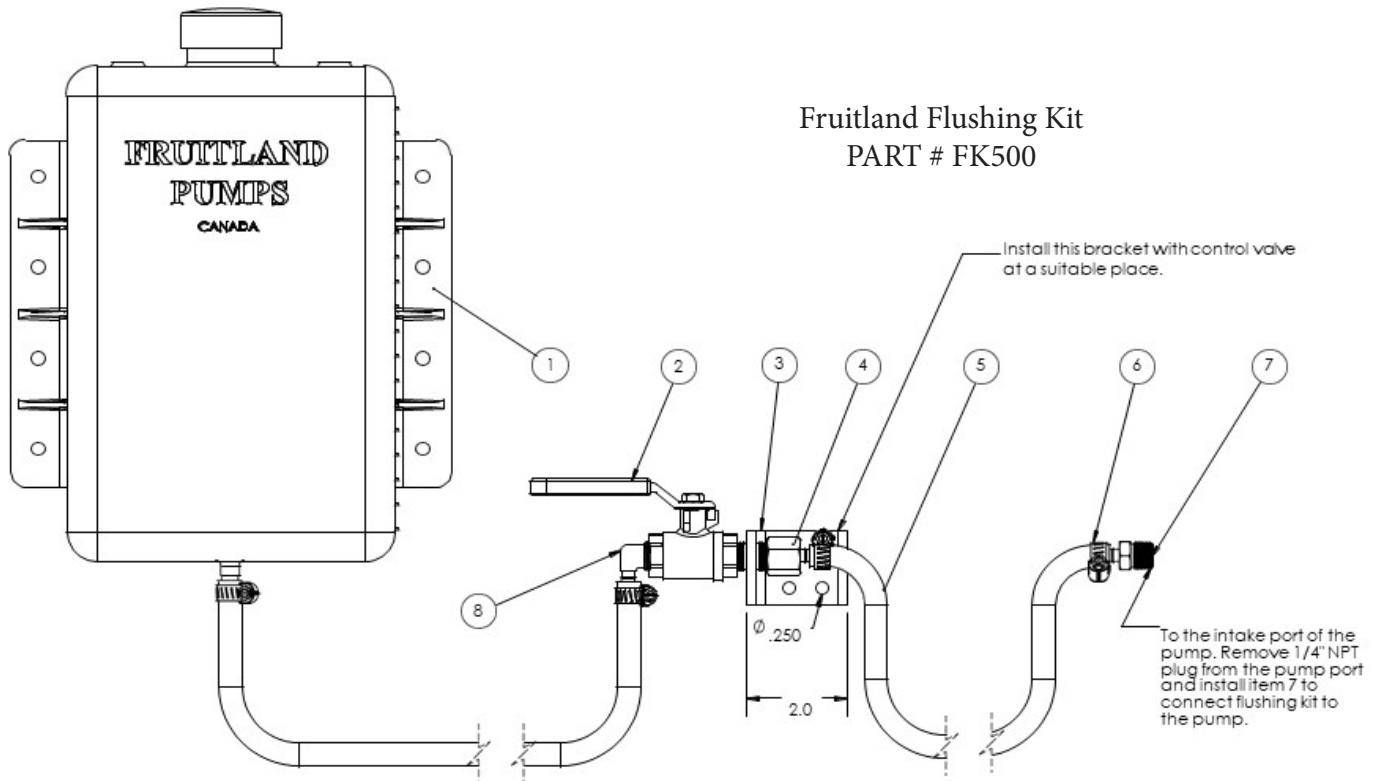

ITEM #	PART #	DESCRIPTION	QTY
1	OR11-A-01	6QT. PLASTIC TANK WITH BREATHER CAP	1
2	FK500-A-01	BALL VALVE, 1/4"	1
3	FK500-01	ANGLE BRACKET FOR REMOTE VALVE INSTL. SEE DWG. FK500-01	1
4	FK500-A-02	STRAIGHT BRASS FITTING, 1/4" NPT FEMALE TO 1/4" ID HOSE BARB	1
5	OR11-A-02	Ø1/4" ID FUEL LINE RUBBER HOSE	10 ft
6	OR11-A-03	HOSE CLAMP 7/32"-5/8" (SAE 4)	4
7	FK500-A-03	STRAIGHT BRASS FITTING 1/4" NPT MALE TO 1/4" ID HOSE BARB	1
8	OR11-A-04	ELBOW 1/4" NPT MALE TO 1/4" ID HOSE BARB FITTING BRASS	1

Flushing Fluid: $\frac{3}{4}$ of diesel fuel mixed with $\frac{1}{4}$ of pump oil by volume

SERVICE NOTE

USE AUTHENTIC FRUITLAND PARTS ONLY!

If you have any questions, or require further information on installing, operating and or the maintenance of your vacuum pump contact:

1-800-663-9003 - info@fruitland-mfg.com - sales@fruitland-mfg.com

VACUUM PUMP & SYSTEM MAINTENANCE

Drain the secondary moisture trap Before Every Pump Operation!!

If the secondary moisture trap is full and or starts to fill, you will lose the ability to create pressure and or vacuum. Check the secondary shut-off before every use by opening the drain valve upon the bottom of this moisture trap. If the secondary trap has any substance within it, this could end up running through the vacuum pump and causing catastrophic pump failure. If any substance is within the secondary shut-off, this indicates the tank is full, over-filled and or the primary shutoff upon your vacuum system is not working correctly.

Check the primary shut-off Daily

The primary shut-off is the first stopping point within the vacuum tank system for the product being loaded into your vacuum tank. This primary shut-off must work correctly every time or the pump & system will fail quickly, and you will certainly have a catastrophic pump failure. Verify each day, before starting, the rubber seat is in proper shape and form, the ball appears to be free of any debris, holes and is operational. The cage in which the ball rests, or sits within must be attached to the primary shut-off assembly correctly.

Clean the Pump Air Filter Daily

Every vacuum pump system should contain a vacuum pump air filter somewhere between the primary shut-off and the vacuum pump. This filter will prevent any foreign objects from being sucked into the vacuum pump through the tank during normal operation. This air filter must be cleaned each day before the operation of the vacuum system. Remove the stainless-steel mesh filter daily from the air filter canister and clean with either soapy water and or diesel fuel.

Drain the oil catch muffler Daily

If the oil catch exhaust muffler starts to expel oil, you will lose vacuum performance. This overflow of oil may backfill into the pump. When draining the muffler system, pay attention to the material being expelled from the muffler's drain valve, this is a good way to spot any water and/or debris that may have entered the vacuum pump system.

Fruitland Oil Reservoir Kit

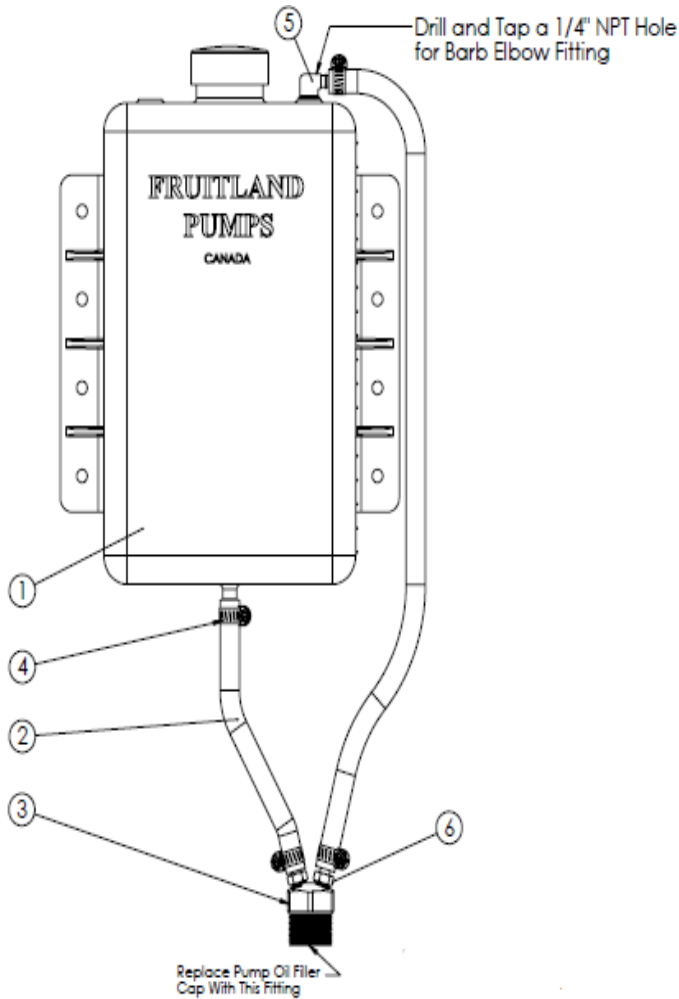

Fruitland Part # OR11 Oil Reservoir Kit includes:

PART #	DESCRIPTION	QTY
OR11-A-01	6 QT. PLASTIC TANK WITH BREATHER CAP AND STRAIGHT 4" BARB FITTING AT BASE	1
OR11-A-02	Ø1/4" ID FUEL LINE RUBBER HOSE 10 FT.	10 ft
OR11-01	3/4" NPT ADAPTER WITH BARB FITTINGS, FTM MACHINED	1
OR11-A-03	HOSE CLAMP 7/32"- 5/8" (SAE 4)	4
OR11-A-04	ELBOW 1/4" NPT TO 1/4" ID HOSE BARB FITTING BRASS	1

Vacuum Pump Storage

It is recommended to complete the Pump Flushing Procedure, upon page 12th, prior to the pump being put into storage and not operational for an extended amount of time (2 or more months).

Following the Pump Flushing Procedure when storing the vacuum pump for an extended amount of time will prolong the vacuum pumps life exponentially.

SERVICE NOTE

USE AUTHENTIC FRUITLAND PARTS ONLY!

If you have any questions, or require further information on installing, operating and or the maintenance of your vacuum pump contact:

1-800-663-9003 - info@fruitland-mfg.com - sales@fruitland-mfg.com

VACUUM PUMP DRIVE SYSTEMS

Do not Over-speed or Under-speed the Vacuum Pump

The Drive System must be sized and calculated correctly. Either over and/or under speeding the vacuum pump drive shaft speed will cause catastrophic pump failure and possibly damage the entire vacuum pump & system.

The Power Take Off - PTO - must allow for the vacuum pump drive shaft to slowly engage. Incorrectly configured and or installed PTO's will deteriorate all drive system components prematurely and may cause damage to the vacuum pump.

The tank truck drive system must be set up or dialed into the correct optimal operational input rpm of the vacuum pump during system & pump installation.

Every vacuum pump model has a different optimum operational rpm. Contact the factory for the correct operational rpm for your vacuum pump model & system.

Fruitland Vacuum Pump RPM & Power Requirements

The table below provides the recommended input speeds and correlating power requirements for each Fruitland Vacuum Pump Model's optimal overall performance.

	HP Requirements												Input RPM	Torque ft-lbf											
	Pressure (psi)						Vacuum (inch Hg)							Pressure (psi)						Vacuum (inch Hg)					
RCF	25	20	15	10	5	0	5	10	15	20	25	28	1375	25	20	15	10	5	0	5	10	15	20	25	28
Pump Model	Engine BHP (30% uprated from actual)												1375	Torque ft-lbf											
870	57	53	51	47	44	40	38	36	38	39	40	42	1375	218	204	194	181	169	154	144	139	144	149	154	159
500	42	39	36	34	31	30	29	27	25	24	23	22	1375	160	149	138	130	118	115	111	103	95	92	88	84
370	36	32	28	23	20	16	15	14	13	13	12	11	1375	138	122	105	88	76	61	57	53	50	48	46	42
344	X	X	19	16	13	11	11	12	13	15	15	X	1375	X	X	73	61	50	41	43	45	49	56	58	X
250	18	17	15	13	12	10	10	9	8	8	8	7	1375	69	63	57	50	46	38	36	34	31	29	29	27
172	X	X	12	9	7	6	6	7	8	8	9	X	1375	X	X	44	35	27	22	24	26	29	29	34	X
RCF	25	20	15	10	5	0	5	10	15	20	25	28	1375	25	20	15	10	5	0	5	10	15	20	25	28
Pump Model	Actual HP												1375	Torque ft-lbf											
870	44	41	39	37	34	31	29	28	29	30	31	32	1375	168	157	149	139	130	118	111	107	111	115	118	122
500	32	30	28	26	24	23	22	21	19	18	18	17	1375	123	115	106	100	91	88	85	79	73	71	68	65
370	28	25	21	18	15	12	12	11	10	10	9	8	1375	106	94	81	68	59	47	44	41	38	37	35	32
344	X	X	15	12	10	8	9	9	10	11	12	X	1375	X	X	56	47	38	32	33	34	38	43	45	X
250	14	13	12	10	9	8	7	7	6	6	6	5	1375	53	48	44	38	35	29	28	26	24	22	22	21
172	X	10	9	7	5	4	5	5	6	6	7	X	1375	X	X	34	27	21	17	18	20	23	23	26	X



ATTENTION

Fruitland Vacuum Pumps should never exceed the input RPM stated on the vacuum pump's plate tag - severe pump & system damage will occur & the pumps warranty will be void.

The largest contributing factor limiting a Fruitland Vacuum Pumps performance is continued heat generation due to operating the pump above and or below the recommended input speed. This additional heat produced due to incorrect RPM Input speed will negatively impact the overall life of your Fruitland pump.

Check the Drive Components of the Vacuum Pump

If using a Fruitland right-angled gearbox verify the gear oil level within the gearbox and clean the vent cap upon the top of the gearbox case during your routine service.

If using a belt and pulley to operate the vacuum pump, check the belts for wear and verify the belt's tension during your routine service.

When incorporating hydraulics ensure the fluid is replaced on a routine basis as the viscosity deteriorates in the same fashion as your engine oil.

Contact the factory for the optimum hydraulic circuit, gearbox and belt specifications for your vacuum pump system.

Fruitland pumps may be run up to 20% slower than the stated RPM on the tag if required.



ATTENTION

Vacuum pump & drive system direction of rotation must be determined and verified prior to procurement of the vacuum pump and all correlating drive system components.



WARNING

Operating your Fruitland vacuum pump without installing the correctly sized drive components can result in misuse of this product that may result in severe injury, death, severe system damage, and or void the pump's warranty. If you have any questions or require further information on installing and or operating your vacuum pump contact:

1-800-663-9003 - info@fruitland-mfg.com - sales@fruitland-mfg.com

Fruitland Drive Couplings - F100 Couplings

PART #	DESCRIPTION	BORE +0.0003 +0.0013	KEY SIZE +0.002 -0.0	SET SCREW SIZE
F100-1000	COUPLING HALF	1	1/4 X 1/4	5/16-16 X 3/8
F100-1250	COUPLING HALF	1.25	1/4 X 1/4	5/16-16 X 3/8
F100-875	COUPLING HALF	0.875	1/4 X 1/4	5/16-16 X 3/8
F100C-1250 ¹	COMPLETE COUPLING SET	1.25 X1.25	1/4 X 1/4	5/16-16 X 3/8
F100C-875 ²	COMPLETE COUPLING SET	1.25 X0.875	1/4 X 1/4	5/16-16 X 3/8

1. For gearbox : Complete coupling with F100-1250 coupling, F100-875 coupling & F100-INS insert.
2. For hydraulic motor : Complete coupling with two F100-875 coupling & F100-INS insert. ()

It is very important to maintain a gap of 0.070" to 0.100" between the two valves of the coupling to achieve proper pump operations and avoid any pump failures. Please use a feeler gauge as shown in the picture to maintain this gap.

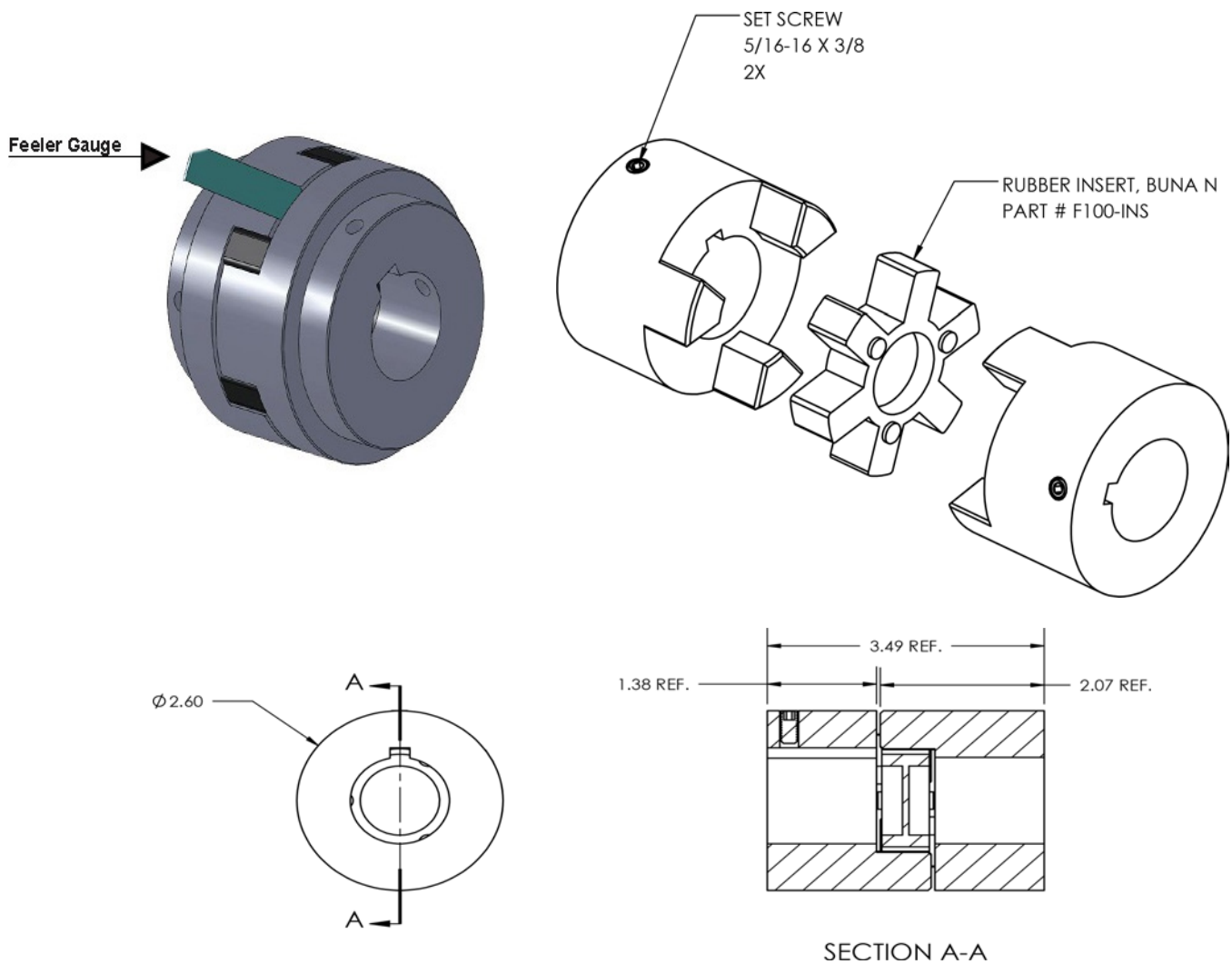

When installing a Fruitland vacuum pump that is to be driven by a hydraulic motor or angle gearbox, the coupling on the pump shaft should be properly aligned and have a sufficient gap clearance of .070" between the two halves of the coupling to allow the rotor to expand lengthwise due to heat. If sufficient clearance is not given, the rotor in the pump will not stay centered in the housing and severe pump damage will occur.



ATTENTION

Do not attempt to install nor service any type of rotating shaft when engine is running or operational. You can snag clothes, skin, hair, hands, etc. This can cause serious injury and or death!

- Do not go under the vehicle when the engine is running
- Do not work near an exposed rotating shaft when the engine is running
- Never work alone while under a vehicle.

FRUITLAND RIGHT ANGLE GEARBOX

Part # RF500-GB400

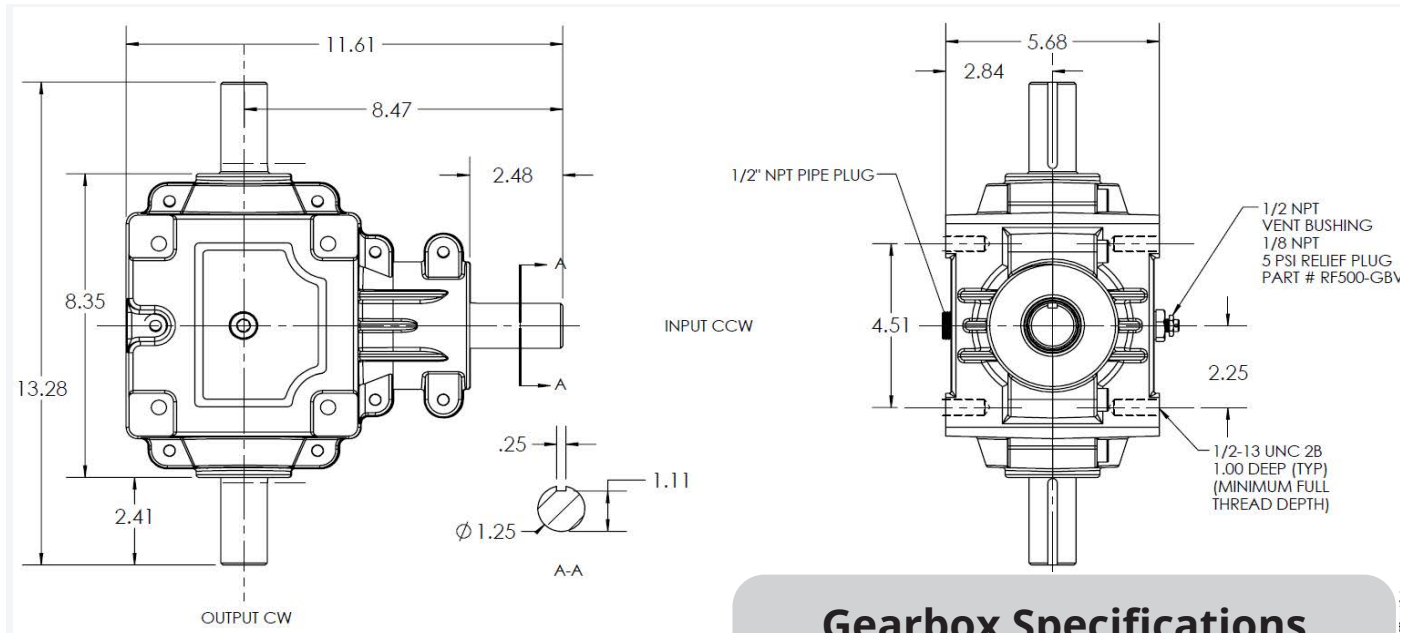

Gearbox Specifications

- Ratio - 1:1
- Input = 1400rpm / 75hp MAXIMUM
- Oil capacity = .775L or 26.2oz
- Weight = 30lbs

Lubrication

All Fruitland Gearboxes are filled with the correct amount of oil. Shaft bearings are splash lubricated and partially submerged in oil when the gear drive is mounted horizontally. The gearbox oil level should be maintained at approximately half the depth of the gearbox housing or to the shaft centerlines.

Lubricants

- Mobilube HD 80W-90 or equivalent in an ambient temperature of 15 to 125 degrees Fahrenheit
- Mobilube synthetic SHC 75W-90 or equivalent in an ambient temperature below 15 degrees Fahrenheit
- Do not combine synthetic and non-synthetic oils
- Average oil temperature should not exceed 200 degrees Fahrenheit

Gearbox Maintenance

Routinely inspect all mounting hardware, drive couplers and any other power transmitting components to ensure all correlating parts are correctly anchored and lubricated. Routine oil change intervals vary depending on the severity of the operational environment. Normal oil change to occur every 250 hours of operation.



ATTENTION

Disconnect power prior to any maintenance and do not bypass or inactivate any safety or protective device. Lock out and tag the main power supply to prevent unexpected application of power. Failure to disconnect power can result in severe injury, death, severe system damage and or void the pumps warranty.

FRUITLAND HYDRAULIC MOTOR

Part # P250-HMBOS

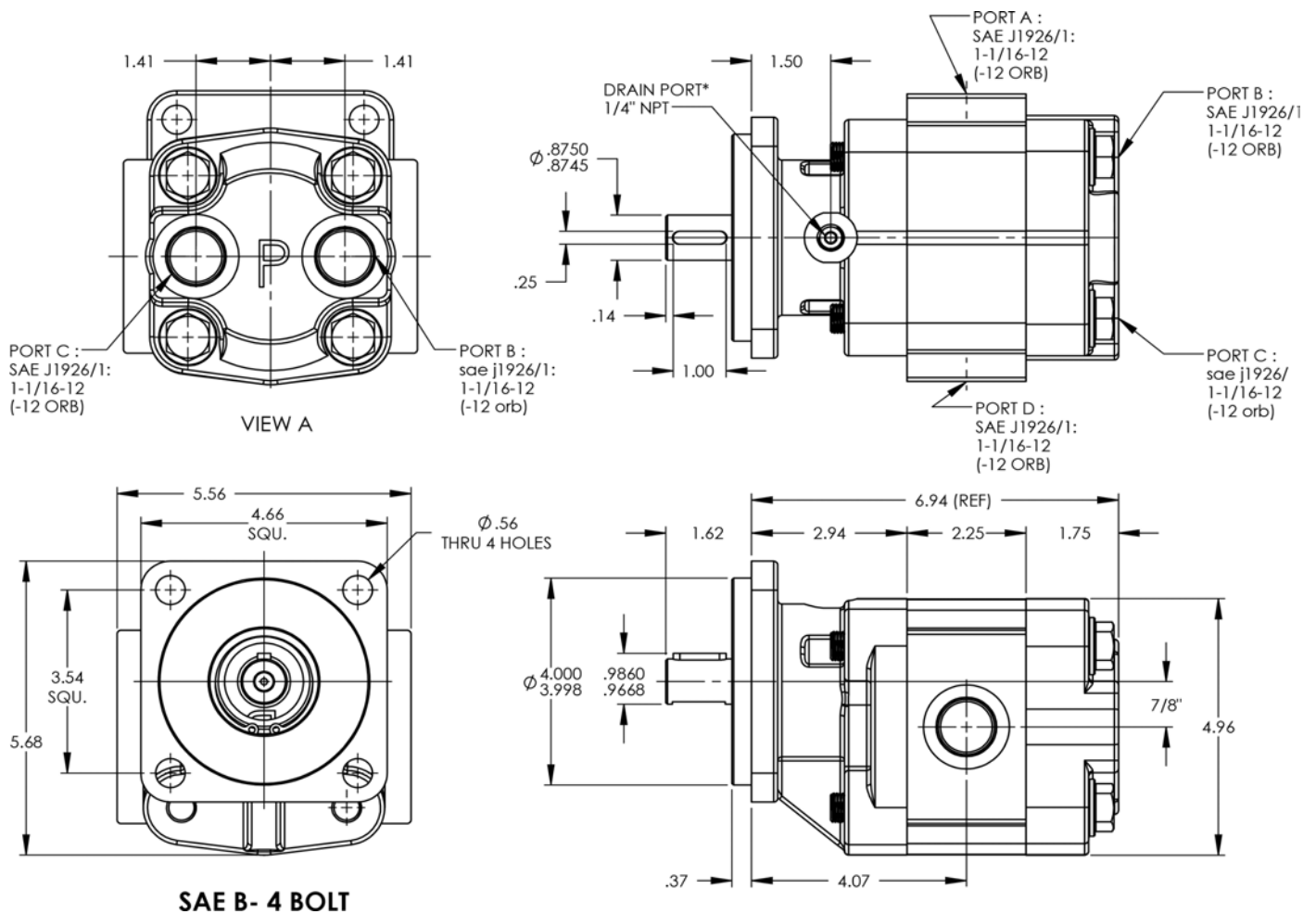

* It is recommended to connect the drain port to the hydraulic oil return line Failure to do so will cause premature seal failures.

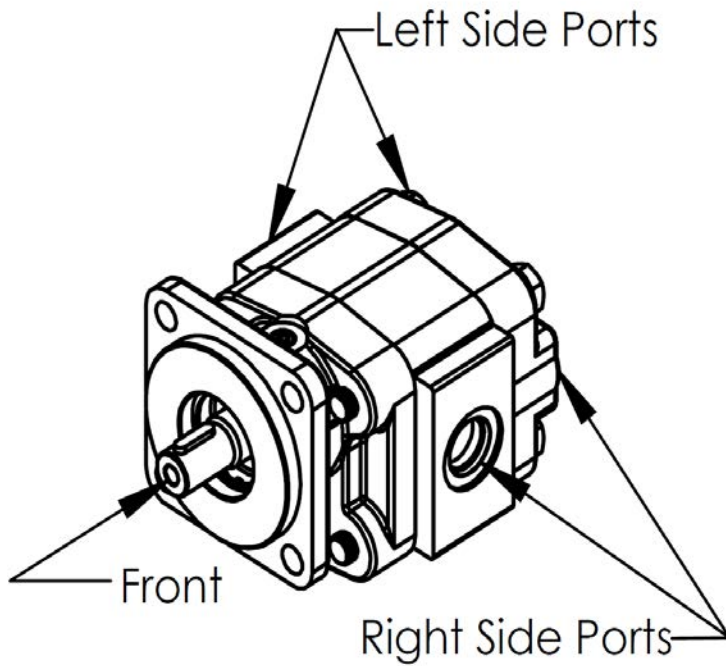

Hydraulic Motor Drive Shaft

KEYED SAE B
 KEY : 1/4"(W) X 3/8"(H) X 1"(L)
 ANSI B17.1

**The motor is bi-directional
 Looking from front,:**

Oil in from left side ports will turn shaft
 CW
 Oil in from right side ports will turn shaft
 CCW.

Hydraulic Motor Requirements:

- RCF172 Hyd. Pump Req.= 18GPM (min.) for 1350 RPM @1100 Psi.
- RCF250 Hyd. Pump Req.= 18GPM (min.) for 1350 RPM @1450 Psi.
- RCF344 Hyd. Pump Req.= 18GPM (min.) for 1350 RPM @1500 Psi



ATTENTION

Disconnect all hydraulic lines prior to any maintenance and do not bypass or inactivate any safety and or protective device. Lock out and tag the engine or main power supply to prevent unexpected application of power. Failure to do so can result in severe injury, death, severe system damage and or void the pumps warranty.

SERVICE NOTE

USE AUTHENTIC FRUITLAND PARTS ONLY!

If you have any questions, or require further information on installing, operating and or the maintenance of your vacuum pump contact:

1-800-663-9003 - info@fruitland-mfg.com - sales@fruitland-mfg.com

DRIVE SHAFT INSTALLATION & PHASING

If your vacuum pump's drive system utilizes a drive-shaft between the PTO and your vacuum pump it is extremely important to verify your angularity and phasing of your drive-line and yokes. Check your drive-shaft angularity and ensure the drive-shaft falls within all the recommendations on the chart below.

It is imperative the PTO shaft is parallel within 1.5 degrees of the pump shaft and or axillary drive shaft or driven unit. Drive-lines must be in phase, that is, the yoke ears on the PTO and the pump shafts must be in alignment as illustrated below.

Maximum Operating Speed - By Tube Size & Solid Shaft Size

(For Speeds below 500 RPM or over 2500 RPM, contact your PTO Manufacturer)

WARNING - Always verify below specifications with your PTO Manufacturer					
Tubing Dia. & Wall Thickness Joint & Shaft (W-Welded S-Seamless)	Max. Installed Length in Inches for Given RPM Centerline to Centerline of Joints for a Two Joint Assembly or Centerline of Joint to Centerline of Center Bearing for a Joint & Shaft RPM - Revolutions per Minute				
	500 RPM	1000 RPM	1500 RPM	2000 RPM	2500 RPM
1750"x.065"W	117"	82"	67"	58"	52"
1250"x.095"S	91"	64"	52"	45"	40"
2500"x.083"W	122"	87"	70"	62"	55"
3000"x.083"W	-	-	-	85"	76"
Solid Shaft Diameter					
0.750"	60"	42"	35"	30"	27"
0.812"	62"	44"	36"	31"	28"
0.875"	65"	46"	37"	32"	29"
1.000"	69"	49"	40"	35"	31"
1.250"	77"	55"	45"	39"	35"

Max. Speed (RPM)	Max. TJA "A"
3500*	5°
3000*	5°
2500	7°
2000	8°
1500	11°
1000	12°

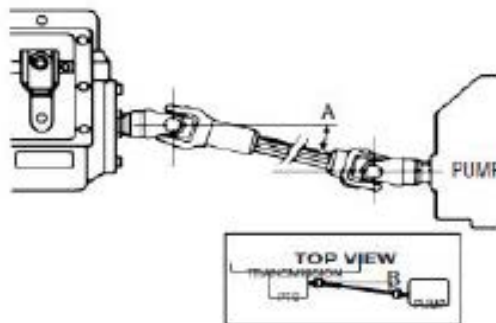

TJA = True Joint Angle - Incorporate this formula to calculate your drive-lines
 True Joint Angle TJA = Square Root of A Squared + B Squared

VANE WEAR MEASUREMENT

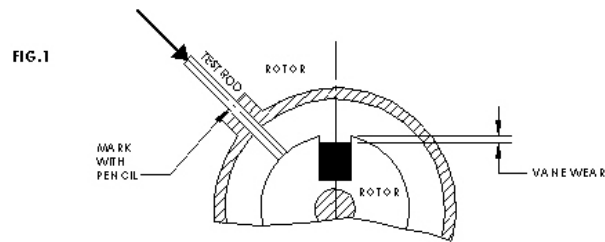

Note: Be extra careful not to bend the checking rod.

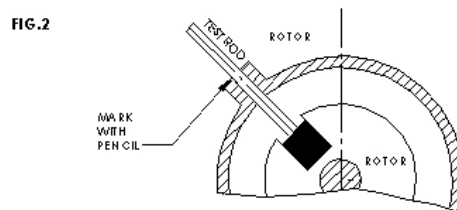

Vane wear (see diagram above) should not exceed 1/4" in pump models 172, 250, 344, 370, 500 and 870. Fruitland pumps have at least two orifices for checking vane wear, some models have four. These orifices are located on the housing at both ends of the vacuum pump, and are marked with red. A 3/16" diameter test rod is supplied with the pump. We recommend checking the vanes on both ends, as they can wear in a tapered fashion because of excess heat or contamination.

To measure vane wear, remove the plug from the orifice and insert the test rod until the rod touches the rotor. Mark the rod with pencil as shown in diagram (fig.1). Turn the pump shaft until the rod drops into the vane slot in the rotor. Mark with pencil again (fig.2). Distance between the pencil marks is the amount of wear you have on the vane. If the vane is tapered from end to end, take the largest measurement as the amount the vane is worn.

Replace the complete set of vanes when worn to the maximum recommended amount for your pump model. Failure to replace the vanes at the recommended time can result in pump failure. Vane wear and subsequent damage are not covered under warranty. Instructions for replacing vanes are given on page 26.

The Recommended first check of vane wear is after approximately 10 hours of operation; next check after 50 hours of operation; thereafter, check every 200 hours or once a month if no significant wear has been detected on the 2 initial checks.

Type	RCF172	RCF 250	RCF344	RCF 370	RCF 500	RCF 870	RCF 1200
Size of Hoses	2"	2"	2"	3"	3"	4"	4"
Max. Operating Speed	1400 RPM	1400 RPM	1400 RPM	1400 RPM	1400 RPM	1400 RPM	1000 RPM
Lubrication (Oil Pump)	Auto	Auto	Auto	Auto	Auto	Auto	Auto
Vanes	4 (fibre)	4 (fibre)	4 (fibre)	8 (fibre)	8 (fibre)	8 (fibre)	8 (fibre)
Fan Cooling Cont. Duty	NO	YES	NO	YES	YES	YES	YES
Approx. Net Pump Weight	128 lbs	255 lbs	182 lbs	385 lbs	450 lbs	525 lbs	1400 lbs
Free Air Flow	127 CFM	166 CFM	218 CFM	272CFM	338 CFM	501 CFM	716 CFM

Vane Wear

Life expectancy of Fruitland fiber vanes is hundreds of working hours. It greatly depends on the cleanliness of the intake air. Any contamination that enters your pump (e.g. sand, rust or soil particles) will shorten their life expectancy. It is the owner's responsibility to keep contamination out of the pump. Keep filters clean.

Many factors can contribute to rapid or premature vane wear:

1. Overheating of the pump (check overheating in trouble shooting page 27)
2. Contamination entering the pump, or anything that can affect the action of the oil such as abrasives, fumes and or chemicals.
3. Running the pump too fast (over and or under speeding) (check rpm of pump drive shaft)
4. Wrong oil or no oil.
5. Oil pump failure.
6. Pump housing damage.
7. Rotor slots worn. If contamination has gotten into the pump and has caused the rotor slots to wear unevenly, extra force is required to return the vanes into the slots as the rotor turns. This extra load can cause housing wear, vane wear and increase the pump temperature.

Vane Replacement

Refer to pump rebuild video at: www.fruitlandmanufacturing.com

- Disconnect drive/power source from pump - Turn engine off !! Put Keys in your pocket !!
- Drain oil from oil tank - inspect for debris & water
- Remove oil tank cover by removing the hex bolts and aluminum sealing washers
- Disconnect all oil lines and remove oil pump. (Held on by two bolts and lock washers).
- Do not lose the oil pump coupling
- Remove the seal housing by removing hex bolts and aluminum sealing washers
- Remove the hex bolts and lock washers from the housing end cap
- Slide the end cap off the rotor shaft.
- The rotor bearing, shims, wave spring, & seals should be kept in order.
- Note their positioning if you remove the bevel springs/washers for replacement
- Remove old vanes and replace with new vanes that have been dipped/soaked in oil
- Inspect housing bore, interior finish & bearings
- We recommend replacing all seals and all related gaskets during this process
- Reassemble in reverse order
- The housing end cap bolts should be tightened evenly to 22 ft./lbs. torque
- Fill oil tank with correct oil & hook up drive/power source
- Resume Operations

Note: Special attention is to be given that the oil pump coupling is engaging the roll pin in the rotor shaft. Turn rotor by hand, it should turn freely.

**Since there are many factors that cause rapid vane wear, we do not warranty vanes or any related damage from vanes worn beyond the recommended amount, unless a defect in material or workmanship caused the vanes to wear prematurely.*

SERVICE NOTE

USE AUTHENTIC FRUITLAND PARTS ONLY!

If you have any questions, or require further information on installing, operating and or the maintenance of your vacuum pump contact:

1-800-663-9003 - info@fruitland-mfg.com - sales@fruitland-mfg.com

TROUBLE SHOOTING PUMP & SYSTEM MALFUNCTIONS

Verify Before Starting:

Visually Inspect the Entire System – Each day before use, make a visual inspection and verify your vacuum pump system has no kinked hoses and or loose connections. Verify all components appear to be in safe operating condition. Verify all drive components appear to be free of any visual defects and or debris. Clean all debris from the vacuum pump, drive system, air filter, and vacuum system shut-off tank components within the tank truck and or tank trailer prior to any operation.

Vacuum Pump does not vacuum:

- Verify vacuum tank and ALL tank components are sealed
- Verify ALL Hose connections and or Hose collapsed and or clogged
- Vacuum pump back up valve assembly has debris within assembly, also causes pump to rotate backwards after stopping.

Pump not turning:

- Damaged/Broken Vane
- Drive System Failure - Inspect all pump drive system components
- Foreign material in vacuum pump
- Pump is FROZEN - Winter Conditions - Avoid vacuum pump FREEZING Problems by dispensing a small amount of diesel fuel into the pump after completion of daily operations

Vacuum Pump Overheating:

- Lack of Oil and or incorrect type of oil - Also - verify oil pump operation
- Input speed - verify pump shaft speed during operation - To High and or To Low
- Clean all exterior surfaces & air filter of vacuum pump
- Exhaust Outlet Reduction or Blockage
- Overall air flow system plumbing sized incorrectly
- Collapsed or Clogged hose
- Filter body needs to be cleaned
- Empty the Oil Catch Muffler
- Empty the Secondary Scrubber/Shut-off
- Worn vacuum pump vanes

VACUUM ACTUATED COOLING SYSTEM (VACS)

Under high vacuum (above 20"hg) very little air moves through a rotary vane vacuum pump. This may result in heat buildup which reduces the duty cycle and under extreme conditions can cause the pump and correlating components to fail prematurely. The Fruitland VACS System allows the pump to remain cool under high vacuum through extended periods of operation. The air injection system for the RCF 344 & 870 vacuum pumps whether installed at the Fruitland factory or by one of our many rig up companies should be installed with an in-line ball valve shut off.

The ball valve should be installed between air injection valve and the filter pod. If a vacuum truck operator chooses to leave vacuum (negative pressure) or pressure in the vacuum tank (vessel) while dis-engaging the Power Take Off (PTO), the operator needs to shut the air injection ball valve off prior to dis-engaging the PTO. Failure to do so may cause the vacuum pump to spin backwards at very high RPM.

Here is how it works:

We take a small pilot air line from the filter pod of the pump directly to the VACS valve. The VACS valve is controlled by the amount of vacuum created by the pump. The valve is factory set at 20" hg but can be adjusted in the field. When the VACS valve starts to open under high vacuum it allows ambient air to enter the pump just ahead of the exhaust port. This will keep the pump operating at a safe temperature in normal operating environments.

The VACS System consists of the air injection valve, 3/8" pilot control tube, 1.5" air injection hose, air filter (optional muffler) and mounting hardware. The valve can be remotely mounted and is extraordinary quiet.

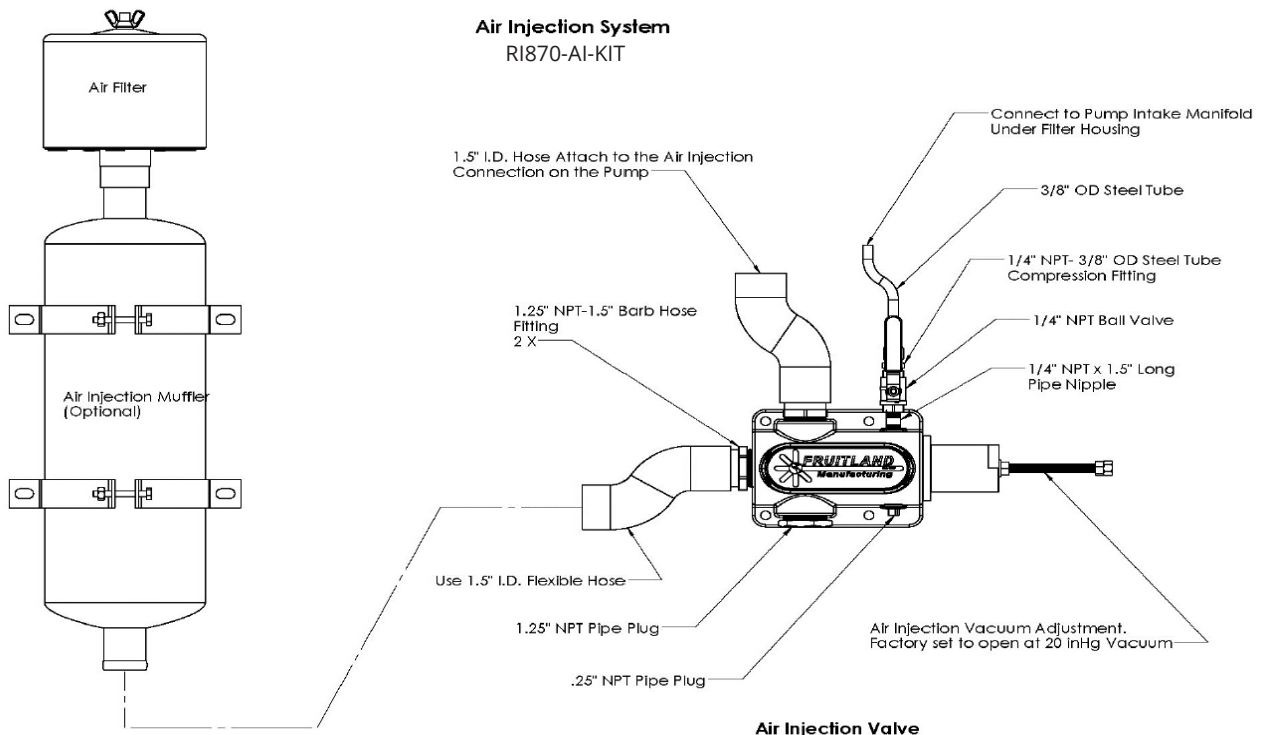

RCF 172 PUMP PARTS & DIMENSIONS



RCF 172 Parts List

ITEM#	PART #	DESCRIPTION	QTY
2	RF500-82A	DRAIN PLUG /VALVE 1/4" NPT	1
7	RF344-225A	OIL SEAL	3
10	250-6	SOLDER FITTING OIL PUMP OUTLET	4
16	RF500-50A	COMPRESSION FITTING 1/8" FOR 1/4"	1
17	RF870-72A	BRASS ELBOW COMPRESSION 1/8" NPT- 1/4" TUBE COMPRESSION	1
21	250-6A	HOLLOW BOLT M6 FOR OIL PUMP	2
22	RF500-27	GASKET - OIL PUMP	1
23	RF500-28A	HEX BOLT M6 X 16MM	4
23A	RF500-280A	LOCKWASHER M6	2
23B	RF344-18A	COPPER FLAT WASHER M6	2
25	RF172-4D	172 ROTOR (DUCTILE IRON)	1
26	RF172-6A	VANES	4
31	RF250-238	DIVERTER INTAKE FLANGE GASKET	1
32	RF250-240	DIVERTER HOUSING	1
35	RF250-248	DIVERTER HOUSING CAP GASKET	1
36	RF250-241	DIVERTER HOUSING CAP	1
37	RF250-250	DIVERTER VALVE LEVER	1
38	RF500-130A	S.H.C. SCREW 1/4"-28 X 43894	1
39	RF250-244A	DIVERTER OIL SEAL	1
40	RF250-246	DIVERTER VANE SPRING	1
41	RF250-251	DIVERTER EXHAUST FLANGE GASKET	1
42	RF250-247A	5/16" x 5/8" DIVERTER VANE SPRING PIN	1
43	RF250-243	DIVERTER VANE	1
44	RF344-BUVD	BACKUP-UP VALVE DISC	1
45	RF344-BUVR	BACK-UP VALVE RING	1
46	RF500-37A	EYEBOLT	1

RCF 172 Parts List Continued

ITEM#	PART #	DESCRIPTION	QTY
47	RF500-137A	M10 HEX NUT	1
48	RF344-40	1.9375 ID INTERNAL RETAINING RING	1
49	RF500-25SG	GLASS SIGHT	2
50	RF500-69A	PIPE PLUG 1/8" NPT BLACK SQ.HD.	2
51	RF500-69A	PIPE PLUG 1/4" NPT BLACK SQ.HD.	4
52	RF500-81	VANE WEAR TEST ROD	1
53	RF500-29	OIL PUMP BI-DIRECTIONAL	1
54	RF344-23	OIL PUMP (RESERVOIR) COVER	1
55	RF344-23A	OIL PUMP (RESERVOIR) COVER O-RING	1
56	RF172-SHIELD	SHIELD FOR OIL PUMP 172	1
58	RF344-039	SEAL HOUSING O-RING	2
60	RF500-72A	ROLL PIN 11810 X 37987 FOR OIL PUMP	1
61	RF344-19A	ROLLER BEARING	2
62	RF344-20A	WAVE SPRING	2
65	RF344-15	SEAL HOUSING DRIVE END	1
66	RF500-GB400K	KEY 1/4" x 1/4" x 1.550"	1
70	RF500-48A	HEX BOLT M8 x 25 MM	10
72	RF870-32A	DOWEL PIN, .375X2.0 LONG	4
73	RF500-80A	OIL PUMP COUPLING	1
80	RF344-21-3A	BEARING SHIMS .003"THK	3
80	RF344-21-5A	BEARING SHIMS .005"THK	3
80	RF344-21-10A	BEARING SHIMS .010"THK	3
100	RF500-67A	M10 X 30MM	15
100A	RF120-94A	10MM LOCK WASHER	15
120	RF500-56A	M10 X 20MM SHCS	6
120A	10MM	HI-COLLAR LOCK WASHER	6

RCF 172 Parts List Continued

ITEM#	PART #	DESCRIPTION	QTY
130	RF172-1	172 HOUSING	1
140	RF344-60	HOUSING END CAP GASKET	2
150	RF344-3	HOUSING END CAP	1
151	RF344-3A	HOUSING END CAP NON DRIVE END	1
170A	RF344-51B	344 INNER OIL LINES	1
190	RF500-190P	BREATHER FILLER	1
560	RF344-22	SEAL HOUSING NON DRIVE END	1
607	RF500-F07	HEX BOLT M8 x 30MM	4
607A	RF120-96A	LOCK WASHER M8	14
INS	RF500-INS	INSTRCTION TAG OIL	1
MAN	RF500-MAN	MANUAL	1
NAM	RF500-NAM	NAME PLATE	1

* SPECIFY PUMP ROTATION "L" OR "R" AND MOUNTING DIRECTION SIDE OR UPRIGHT.

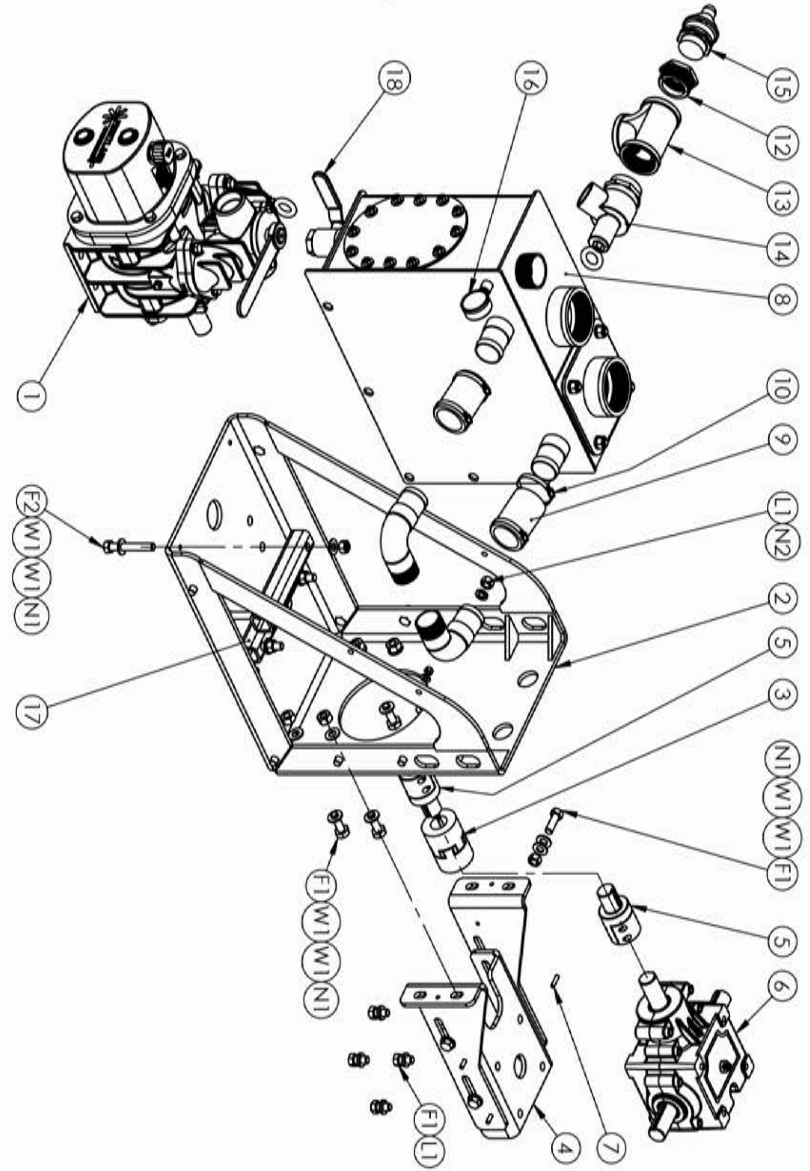
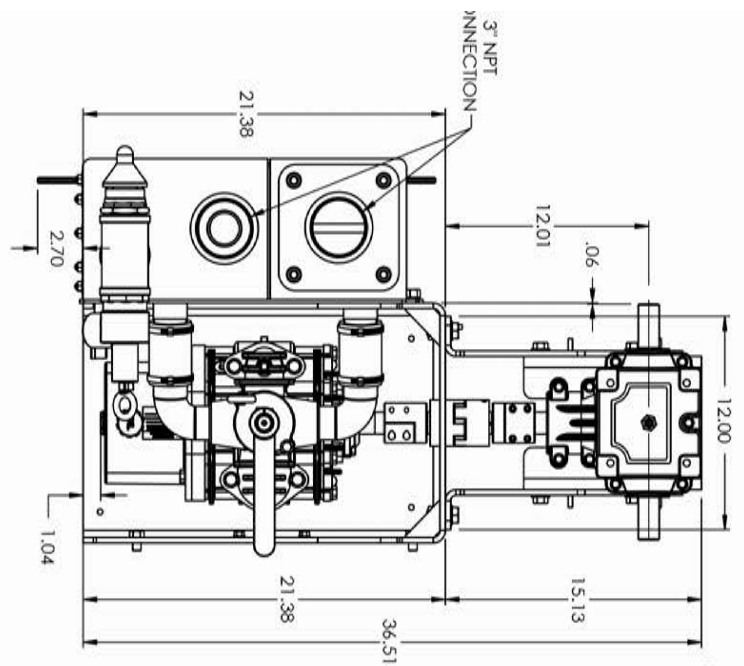
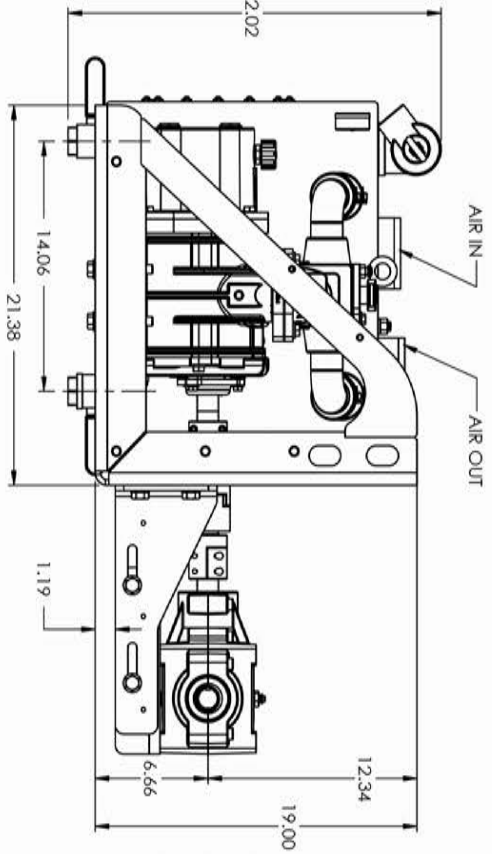
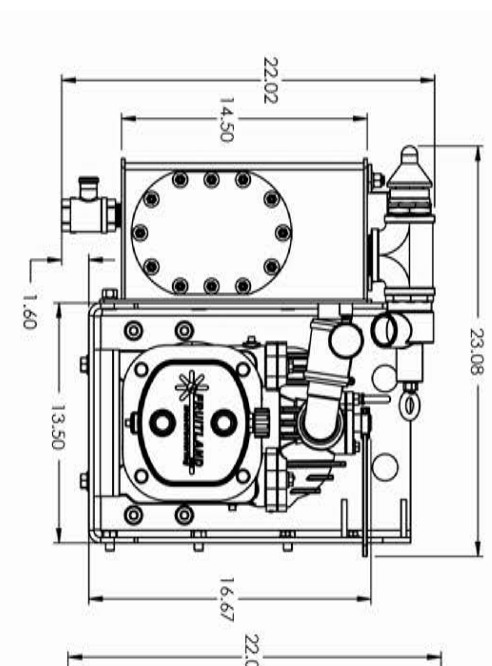

DWG IS FOR REFERENCE ONLY
 WE RESERVE THE RIGHTS TO
 MAKE CHANGES
 REF: DWG# ELIM A-SMF172RL



ELIM A-SMF172RL Parts List

ITEM#	PART #	DESCRIPTION	QTY
1	172RU	RCF172 VACUUM PUMP	1
2	PF18-PT-L	344-PT PEDASTAL FRAME-LEFT	1
3	F100-A	F100 COMPLETE COUPLING WITH BUNA INSERT BORES: 1.25 X 1.25 PUMP AND GB	1
4	ADM18	344-PT ANGLE DRIVE MOUNT	1
5	RF250-SA	1-1/2' DIA. SHAFT EXTENSION ADAPTOR	-
5	RF250-SA	PCS. USED WITH 12" SHAFT DISTANCE (GEAR BOX)	2
5	RF250-SA	PC. USED WITH 8" SHAFT DISTANCE (GEAR BOX)	1
6	RF500-GB400	RIGHT ANGLE GEAR BOX	1
7	1/4" X 1" LG SPLIT PIN	1/4" X 1" SPLIT PIN	6
8	SM12-250C-PT-L	250-PT-LEFT SECONDARY MUFFLER ASSM	1
9	2" HOSE	Ø2" RUBBER HOSE 4" LG.	2
10	2" HOSECLAMP	CLAMPS FOR RUBBER HOSE (M10 64-67mm)	4
11	FA250C	DIVERTER ELBOW DWG# SM12-FA	2
12	RF250-75A	2" MALE X 1.5" FIMALE, HEX BUSHING	1
13	RF250-76A	2" NPT TEE	1
14	2" PRV	PRESSURE RELIEF VALVE 2" NPT	1
15	VB	VACUUM RELIEF VALVE 1-1/2" NPT	1
16	PVG-2.5	PRESSURE VACCUM GAGE	1
17	Elim A344-PT-SB-T	SPACER TUBE FOR HOUSING (ELIM A344-PT)	2
18	M09-A-07	1" NPT BALL VALVE	2
F1	1/2" X 1-1/2"	1/2" NC 1.5" LONG ZINC PLATED HEX HEAD BOLTS	12
F2	1/2" X 3-1/2"	1/2" NC 3.5" LONG ZINC PLATED HEX HEAD BOLTS	4
W1	1/2" FLAT WASHER	1/2" Z.P. FLAT WASHER	16
L1	1/2" L/W	1/2" LOCK WASHERS ZINC PLATED	4
N1		1/2" NC NYLOCK HEX NUT	8
N2	1/2" NUTS	1/2" NC ZINC PLATED HEX NUT	4

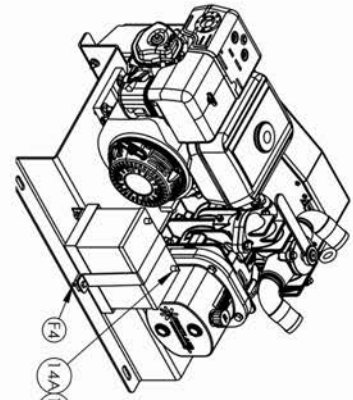

- F4
- 14A
- 14B
- 14C
- 14D
- 14E
- 14F

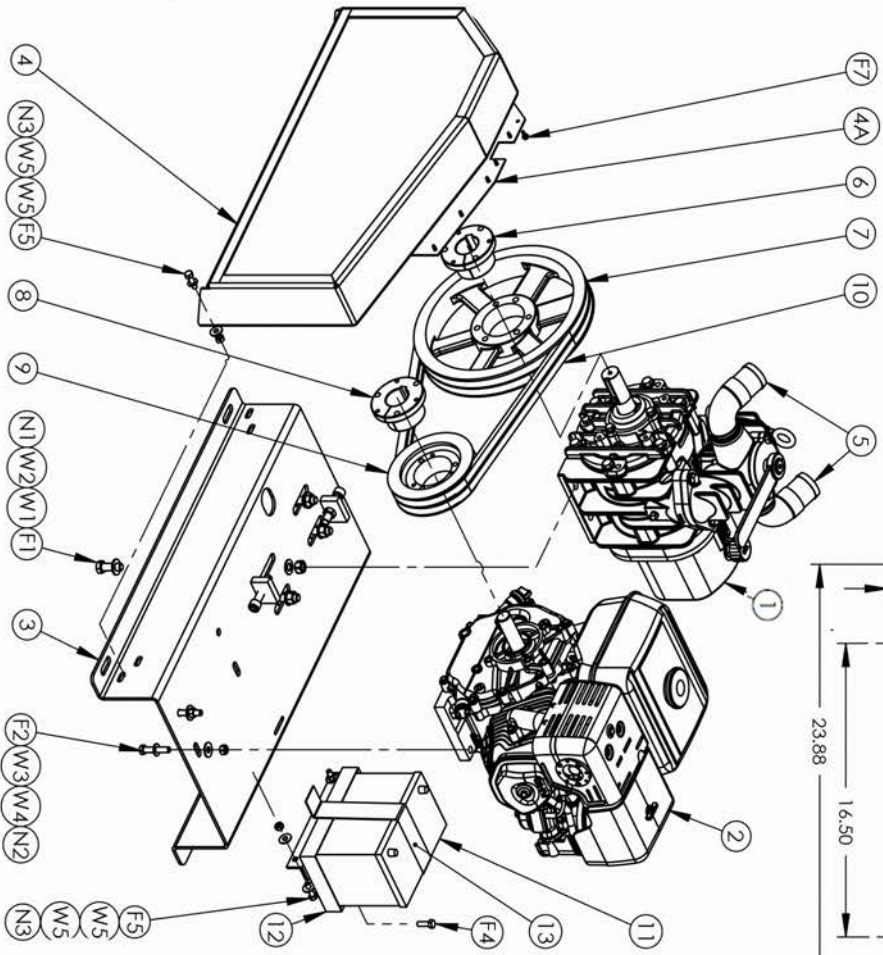
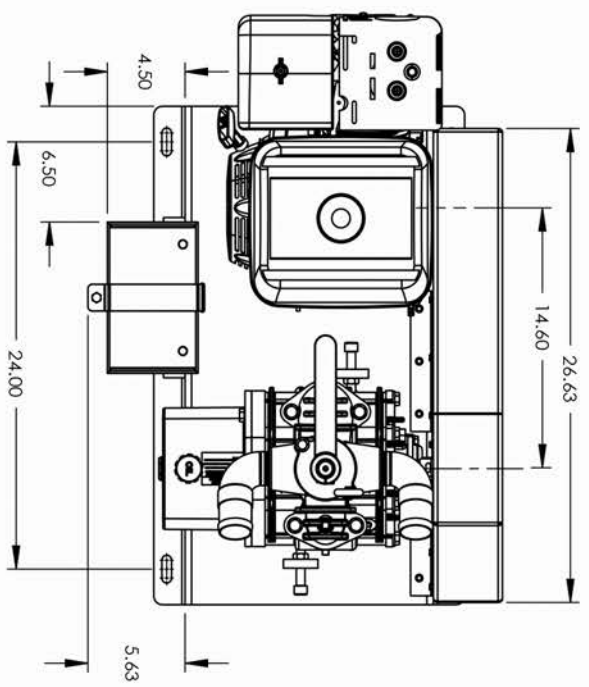
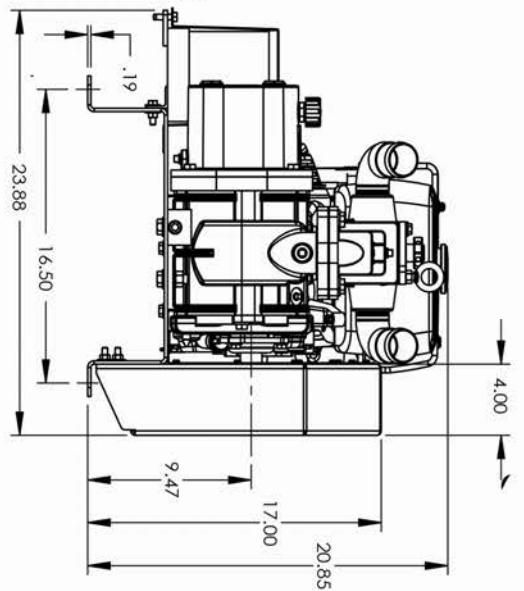

- F7
- 4A
- 6
- 7
- 10
- 5
- 1
- 2
- 11
- 13
- F4
- 12
- F5
- W5
- W5
- N3
- 4
- N3
- W5
- W5
- F5
- 8
- 9
- N1
- W2
- W1
- F1
- 3
- F2
- W3
- W4
- N2

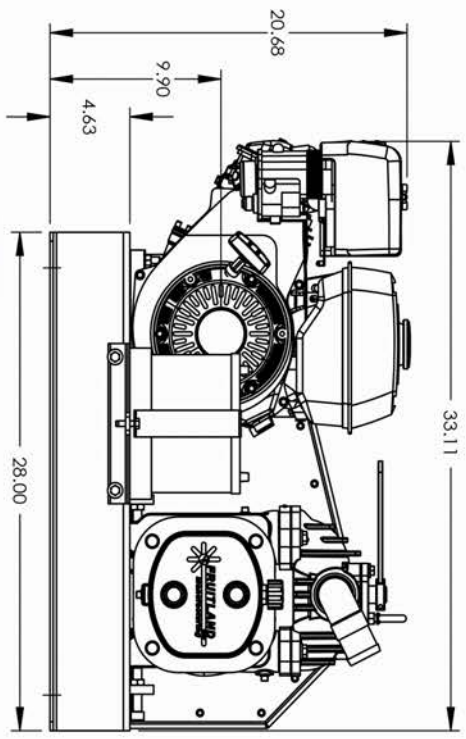

DWG IS FOR REFERENCE ONLY
 WE RESERVE THE RIGHTS TO
 MAKE CHANGES

REF: DWG# ELIM G172L DIMS
 ELIM G172L BOM



ELIM G172L Parts List

ITEM#	PART #	DESCRIPTION	QTY
1	172LU	RCF172 VACUUM PUMP	1
2	FX420	FRUITLAND FX420 WITH ELECTRIC START	1
3	ELIM-G172-01	ELIM G344 BASE FRAME ASSEMBLY	1
4	ELIM-G250-02	ELIM G250 BELT GUARD	1
4A	ELIM G344-024	G344 BELT GUARD WIRE MESH	1
5	FA250C	DIVERTER ELBOW	2
6	SF1.25	SF BUSHING FOR 1.25" SHAFT. 1/4" KEY	1
7	2B12.4L	SHEAVE 12.4 SF 2 GROOVE B SECT.	1
8	SK1.0	SK BUSHING FOR 1" SHAFT. 1/4" KEY	1
9	2B6.0	6" SHEAVE 2 GROOVE B SECT.	1
10	ELIM-G250-03	B57 V-BELT	2
11	ELIM-G250-04	BATTERY	1
12	ELIM-G250-06	BATTERY FRAME	1
13	ELIM-G250-041	BATTERY HOLD DOWN CLAMP	1
14A	ELIM-G250-042	8 GA BATTERY WIRE BLACK, 16" LG.	1
14B	ELIM-G250-043	8 GA BATTERY WIRE RED, 14" LG.	1
14C	ELIM-G250-044	8 GA COPPER EYELET	2
14D	ELIM-G250-045	BATTERY TERMINAL BOOT BLACK	1
14E	ELIM-G250-046	BATTERY TERMINAL BOOT RED	1
14F	ELIM-G250-047	STARTER SOLENOID TERMINAL BOOT RED	1
F1	1/2" X 1-1/2" HEX HEAD	1/2" NC 1-1/2" LONG ZINC PLATED HEX HEAD BOLTS	4
W1	1/2" F/W-USS	1/2" ZINC PLATED FLAT WASHERS, LARGE	4
W2	1/2" F/W-SAE	1/2" ZINC PLATED FLAT WASHERS, SMALL	4
N1	1/2" NYLOCK NUTS	1/2" NC NYLOCK HEX NUT	4
F2	3/8" X 2"	3/8" NC 2" LONG ZINC PLATED HEX HEAD BOLTS	4
W3	3/8" F/W-USS	3/8" ZINC PLATED FLAT WASHERS, LARGE	4

ELIM G172L Parts List Continued

ITEM#	PART #	DESCRIPTION	QTY
W4	3/8" F/W-SAE	3/8" ZINC PLATED FLAT WASHERS, SMALL	4
N2	3/8" NYLOCK NUTS	3/8" NC NYLOCK HEX NUT	4
F4		5/16"NC 1" LONG FLAX FLANGE SERRATED BOLTS	1
F5	5/16"X1" HEX BOLT	5/16" NC 1" LONG ZINC PLATED HEX HEAD BOLTS	6
W5	5/16"WASHER	5/16" ZINC PLATED FLAT WASHERS	12
N3	5/16" NYLOCK NUTS	5/16" NC NYLOCK HEX NUT	6
F7		#10, 1/2" LG, #2 DRILL TYP DRILLIG SCREW FOR METAL	15

SERVICE NOTE

USE AUTHENTIC FRUITLAND PARTS ONLY!

If you have any questions, or require further information on installing, operating and or the maintenance of your vacuum pump contact:

1-800-663-9003 - info@fruitland-mfg.com - sales@fruitland-mfg.com

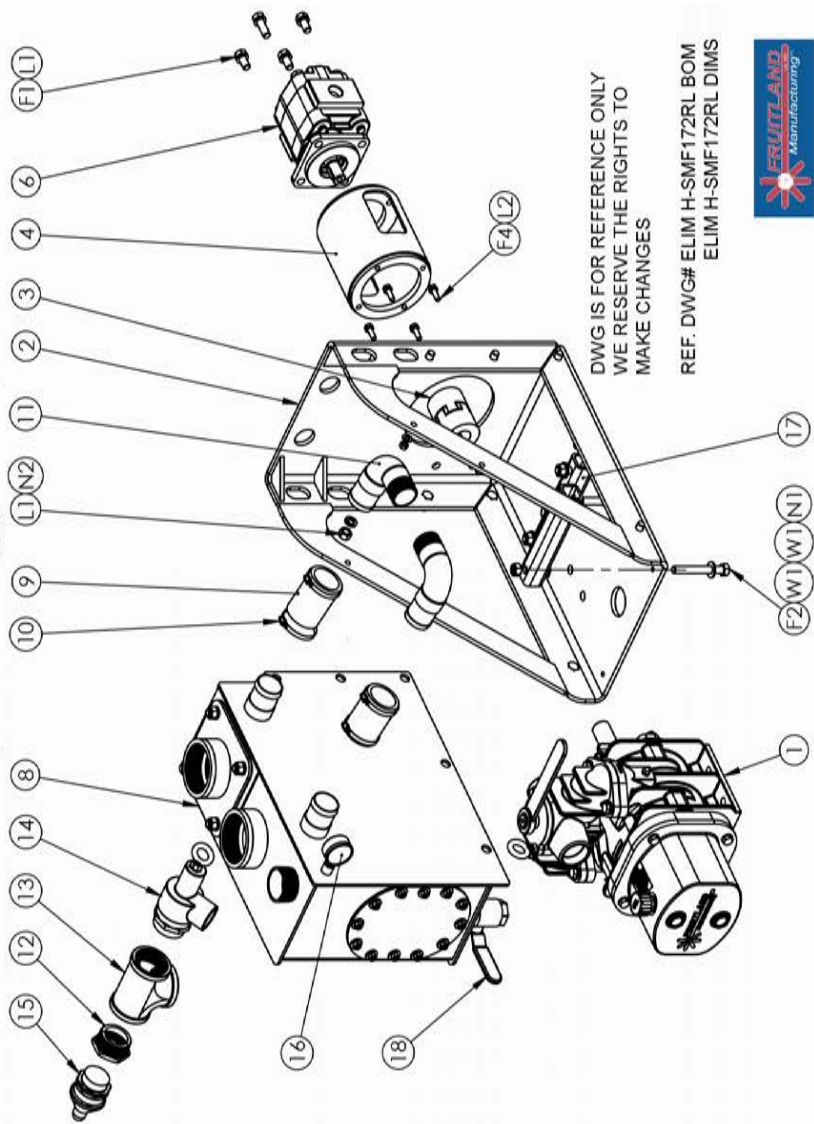
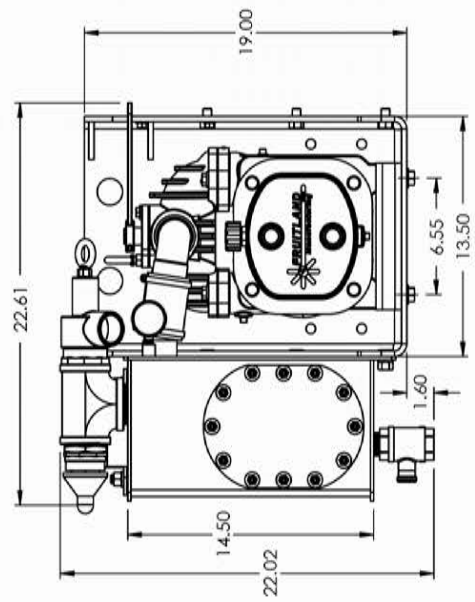
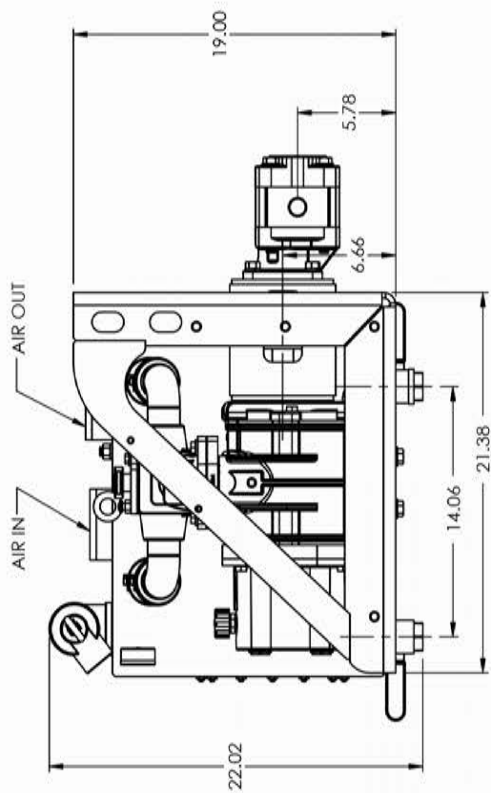
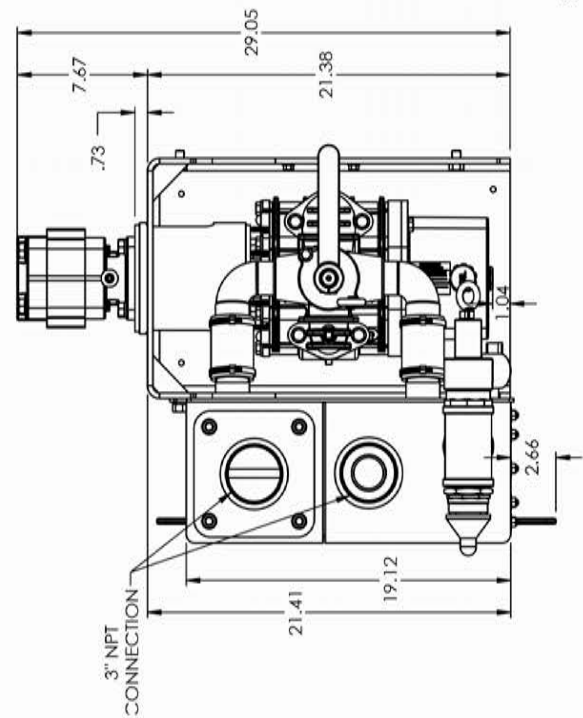

DWG IS FOR REFERENCE ONLY
WE RESERVE THE RIGHTS TO
MAKE CHANGES

REF. DWG# ELIM H-SMF172RL BOM
ELIM H-SMF172RL DIMS



ELIM H-SMF172RL Parts List

ITEM#	PART #	DESCRIPTION	QTY
1	172RU	RCF172 VACUUM PUMP	1
2	PF18-PT-L	344-PT PEDASTAL FRAME-LEFT	1
3	F100-H	F100 COMPLETE COUPLING WITH BUNA INSERT BORES: 1.25 X 0.875 PUMP AND HYD MOTOR	1
4	RF344-HMA	344-PT HYDRAULIC MOTOR ADAPTOR	1
6	P250-HM	HYDRAULIC MOTOR	1
8	SM12-250C-PT-L	250-PT-LEFT SECONDARY MUFFLER ASSM	1
9	2" HOSE	Ø2" RUBBER HOSE, 4" LG.	2
10	2" HOSECLAMP	CLAMPS FOR RUBBER HOSE (M10 64-67mm)	4
11	FA250C	DIVERTER ELBOW DWG# SM12-FA	2
12	RF250-75A	2" MALE X 1.5" FEMALE, HEX BUSHING	1
13	RF250-76A	2" NPT TEE	1
14	2" PRV	PRESSURE RELIEF VALVE 2" NPT	1
15	VB	VACUUM RELIEF VALVE 1-1/2" NPT	1
16	PVG-2.5	PRESSURE VACUUM GAGE	1
17	Elim A344-PT-SB-T	SPACER TUBE FOR HOUSING (ELIM A344-PT)	2
18	M09-A-07	1" NPT BALL VALVE	2
F1	1/2" X 1"	1/2" NC 1" LONG ZINC PLATED HEX HEAD BOLTS	4
F2	1/2" X 3.5"	1/2" NC 3.5" LONG ZINC PLATED HEX HEAD BOLTS	4
F4	RF500-48A	HEX BOLT M8x25	4
W1	1/2" FLAT WASHER	1/2" Z.P. FLAT WASHER	8
L1	1/2" L/W	1/2" LOCKWASHERS ZINC PLATED	8
L2	RF120-96A	LOCK WASHER M8	4
N1		1/2" NC NYLOCK HEX NUT	4
N2	1/2"NUTS	1/2" ZINC PLATED NC HEX NUT	4

RCF 344 PUMP PARTS & DIMENSIONS



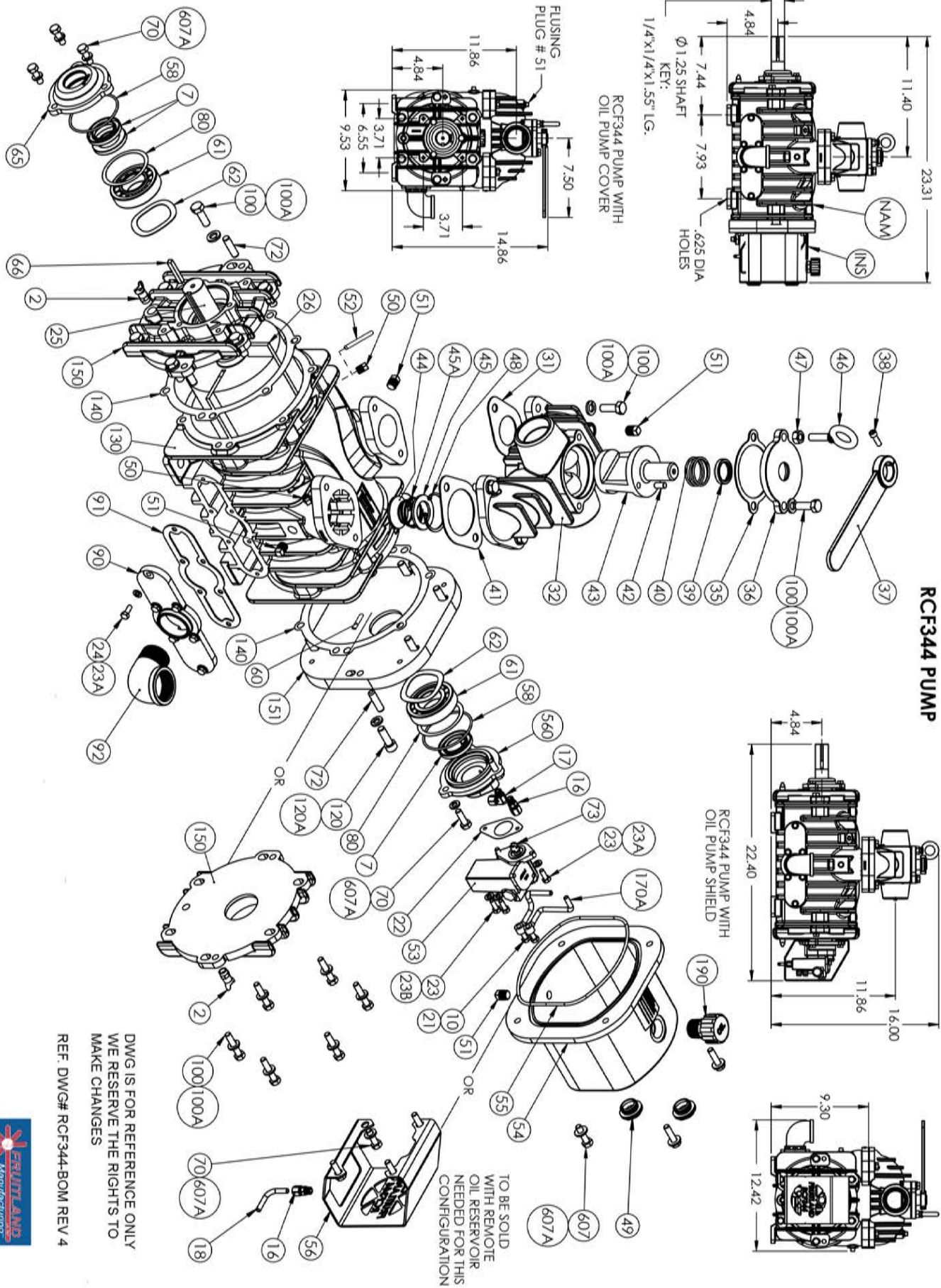

DWG IS FOR REFERENCE ONLY
WE RESERVE THE RIGHTS TO
MAKE CHANGES

REF: DWG# RCF344-BOM REV 4



RCF 344 Parts List

ITEM#	PART #	DESCRIPTION	QTY
2	RF500-82A	DRAIN PLUG /VALVE 1/4" NPT	1
7	RF344-225A	OIL SEAL	3
10	250-6	SOLDER FITTING OIL PUMP OUTLET	4
16	RF500-50A	COMPRESSION FITTING 1/8" FOR 1/4"	1
17	RF870-72A	BRASS ELBOW COMPRESSION 1/8" NPT- 1/4" TUBE COMPRESSION	1
21	250-6A	HOLLOW BOLT M6 FOR OIL PUMP	2
22	RF500-27	GASKET - OIL PUMP	1
23	RF500-28A	HEX BOLT M6 X 16MM	4
23A	RF500-280A	LOCKWASHER M6	8
23B	RF344-18A	COPPER FLAT WASHER M6	2
24	RF500-49A	HEX BOLT M6 X 20MM	6
25	RF344-4	344 ROTOR ASSEMBLY	1
26	RF344-6A	VANES	4
31	RF250-238	DIVERTER INTAKE FLANGE GASKET	1
32	RF250-240	DIVERTER HOUSING	1
35	RF250-248	DIVERTER HOUSING CAP GASKET	1
36	RF250-241	DIVERTER HOUSING CAP	1
37	RF250-250	DIVERTER VALVE LEVER	1
38	RF500-130A	S.H.C. SCREW 1/4"-28 X 43894	1
39	RF250-244A	DIVERTER OIL SEAL	1
40	RF250-246	DIVERTER VANE SPRING	1
41	RF250-251	DIVERTER EXHAUST FLANGE GASKET	1
42	RF250-247A	5/16" x 5/8" DIVERTER VANE SPRING PIN	1
43	RF250-243	DIVERTER VANE	1
44	RF344-BUVD	BACKUP-UP VALVE DISC	1
45	RF344-BUVR	BACK-UP VALVE RING	1

RCF 344 Parts List Continued

ITEM#	PART #	DESCRIPTION	QTY
45A	RF344-66A	BACK-UP VALVE SPRING	1
46	RF500-37A	EYEBOLT	1
47	RF500-137A	M10 HEX NUT	1
48	RF344-40	INTERNAL RETAINING RING FOR BU VALVE	1
49	RF500-25SG	GLASS SIGHT	2
50	RF500-69A	PIPE PLUG 1/8" NPT BLACK SQ.HD.	2
51	RF500-69A	PIPE PLUG 1/4" NPT BLACK SQ.HD.	4
52	RF500-81	VANE WEAR TEST ROD	1
53	RF500-29	OIL PUMP BI-DIRECTIONAL	1
54	RF344-23	OIL PUMP (RESERVOIR) COVER	1
55	RF344-23A	OIL PUMP (RESERVOIR) COVER O-RING	1
56	RF344-SHIELD	SHIELD FOR OIL PUMP 344	1
58	RF344-039	SEAL HOUSING O-RING	2
60	RF500-72A	ROLL PIN 11810 X 37987 FOR OIL PUMP	1
61	RF344-19A	ROLLER BEARING	2
62	RF344-20A	WAVE SPRING	2
65	RF344-15	SEAL HOUSING DRIVE END	1
66	RF500-GB400K	KEY 1/4" x 1/4" x 1.550"	1
70	RF500-48A	HEX BOLT M8 x 25 MM	10
72	RF870-32A	DOWEL PIN, 0.375 X 2 LONG	4
73	RF500-80A	OIL PUMP COUPLING	1
80	RF344-21-3A	BEARING SHIMS .003"THK	3
80	RF344-21-5A	BEARING SHIMS .005"THK	3
80	RF344-21-10A	BEARING SHIMS .010"THK	3
90	RF344-16	BACK-UP VALVE BALLAST AIR PORT COVER	1

RCF 344 Parts List Continued

ITEM#	PART #	DESCRIPTION	QTY
91	RF344-63	GASKET - BALLAST COVER	1
92	RF870-71A	1-1/4" NPT STREET ELBOW	1
100	RF500-67A	M10 X 30MM	15
100A	RF120-94A	10MM LOCK WASHER	15
120	RF500-56A	M10 X 30MM SHCS	6
120A	10MM	HI-COLLAR LOCK WASHER	6
130	RF344-1	344 HOUSING	1
140	RF344-60	HOUSING END CAP GASKET	2
150	RF344-3	HOUSING END CAP	1
151	RF344-3A	HOUSING END CAP NON DRIVE END	1
170A	RF344-51B	344 INNER OIL LINES	1
190	RF500-190P	BREATHER FILLER	1
560	RF344-22	SEAL HOUSING NON DRIVE END	1
607	RF500-F07	HEX BOLT M8 x 30MM	4
607A	RF120-96A	LOCK WASHER M8	14
INS	RF500-INS	INSTRUCTION TAG OIL	1
MAN	RF500-MAN	MANUAL	1
NAM	RF500-NAM	NAME PLATE	1

PART # ELIM A-SMF344RL

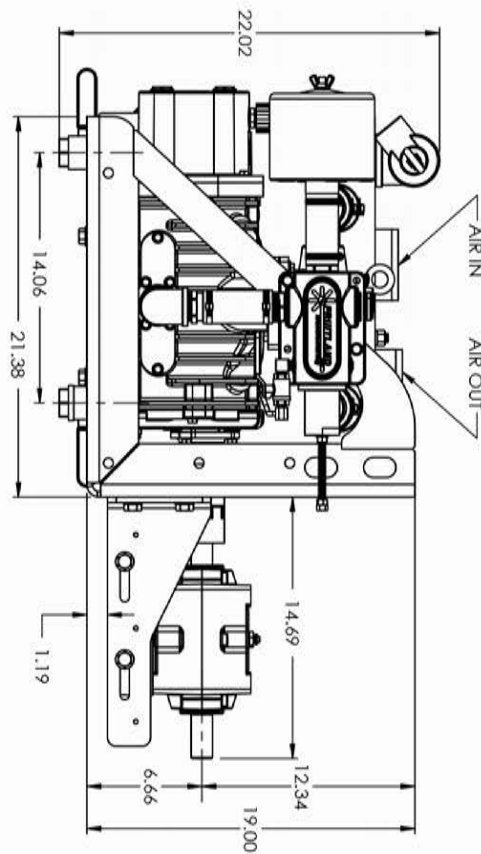
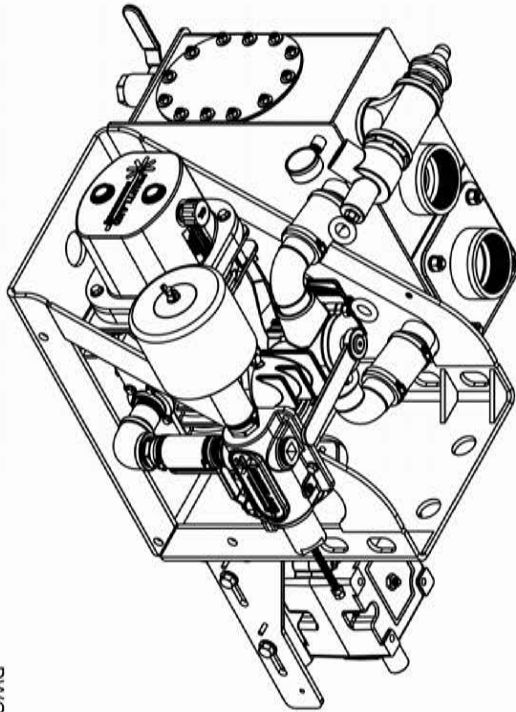
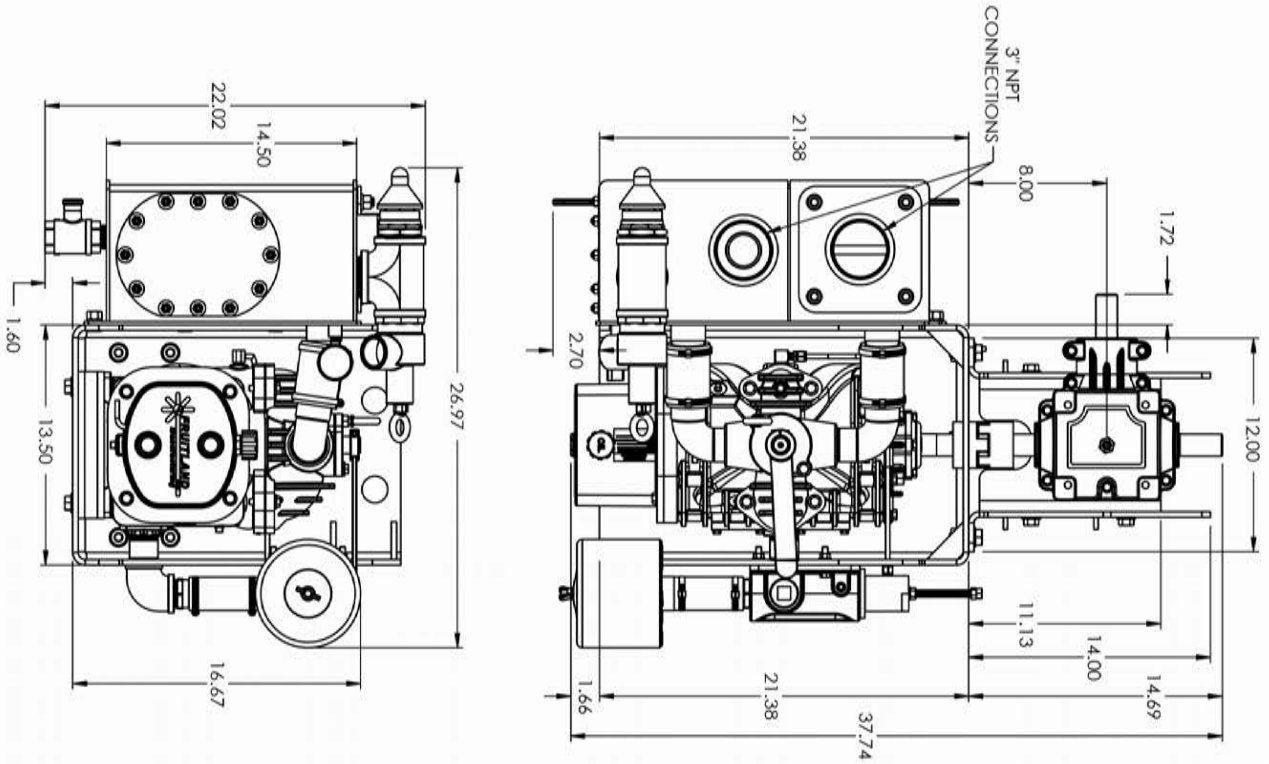

DWG IS FOR REFERENCE ONLY
WE RESERVE THE RIGHTS TO
MAKE CHANGES
REF. DWG# ELIM A-SMF344RL



PART # ELIM A-SMF344RL

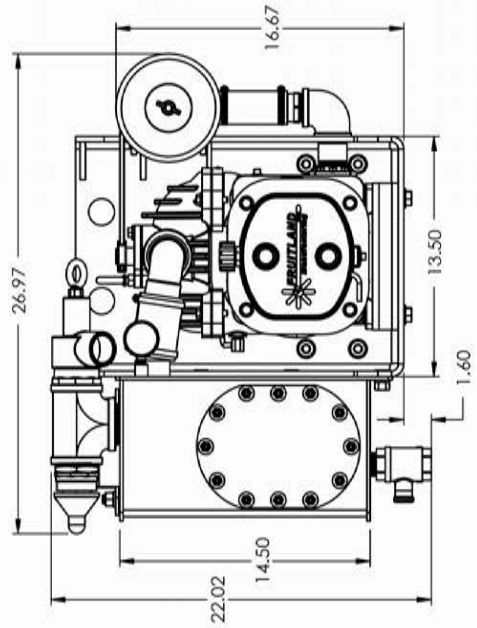
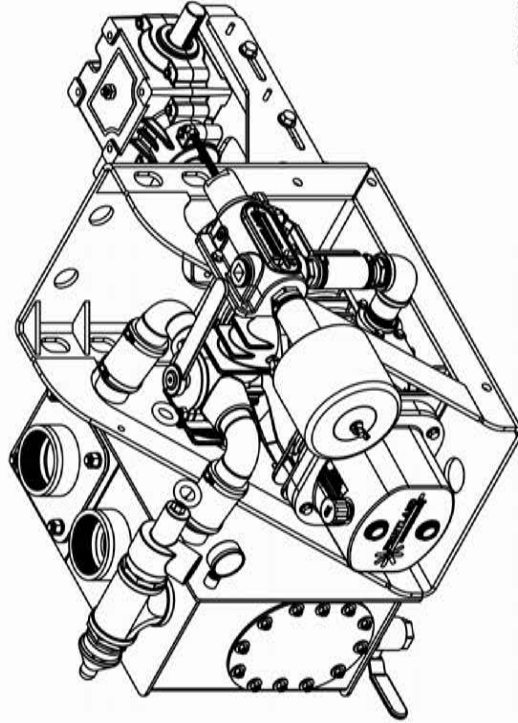
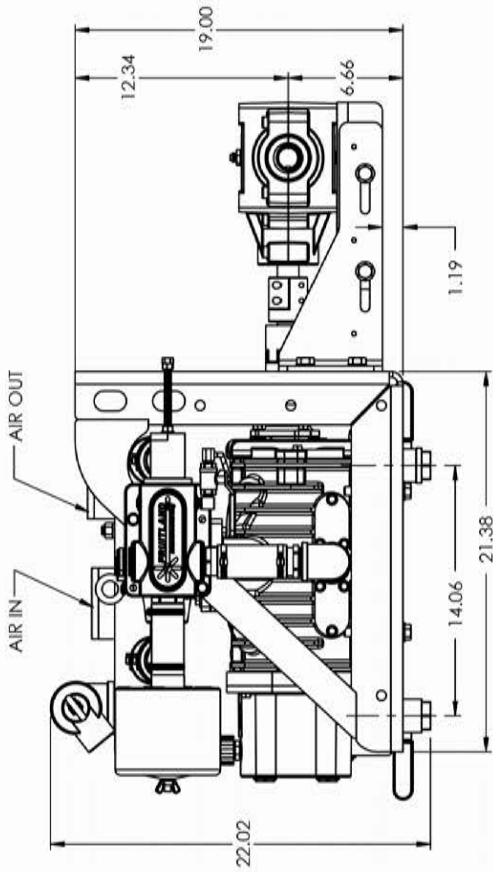
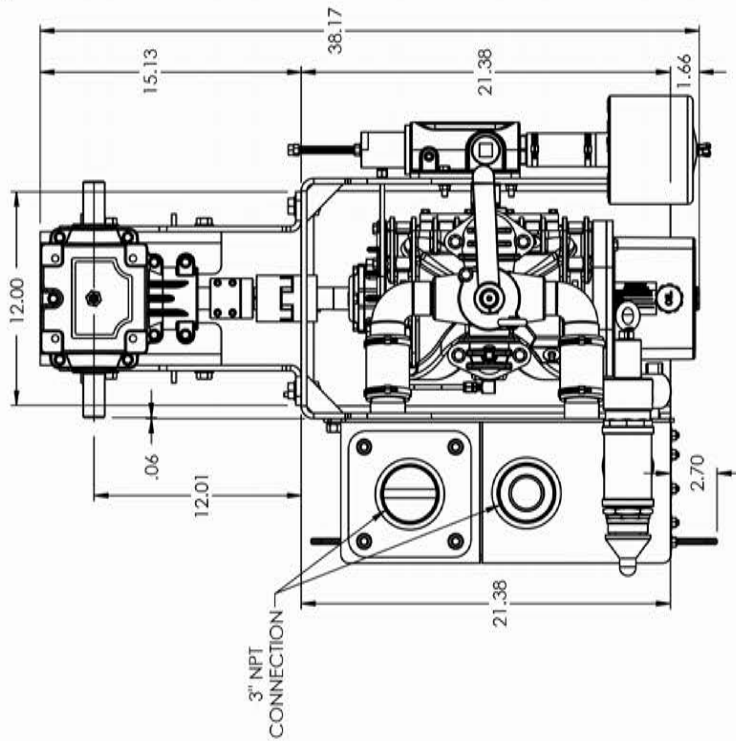

DWG IS FOR REFERENCE ONLY
WE RESERVE THE RIGHTS TO
MAKE CHANGES

REF. DWG# ELIM A-SMF344RL



PART # ELIM A-SMF344RL

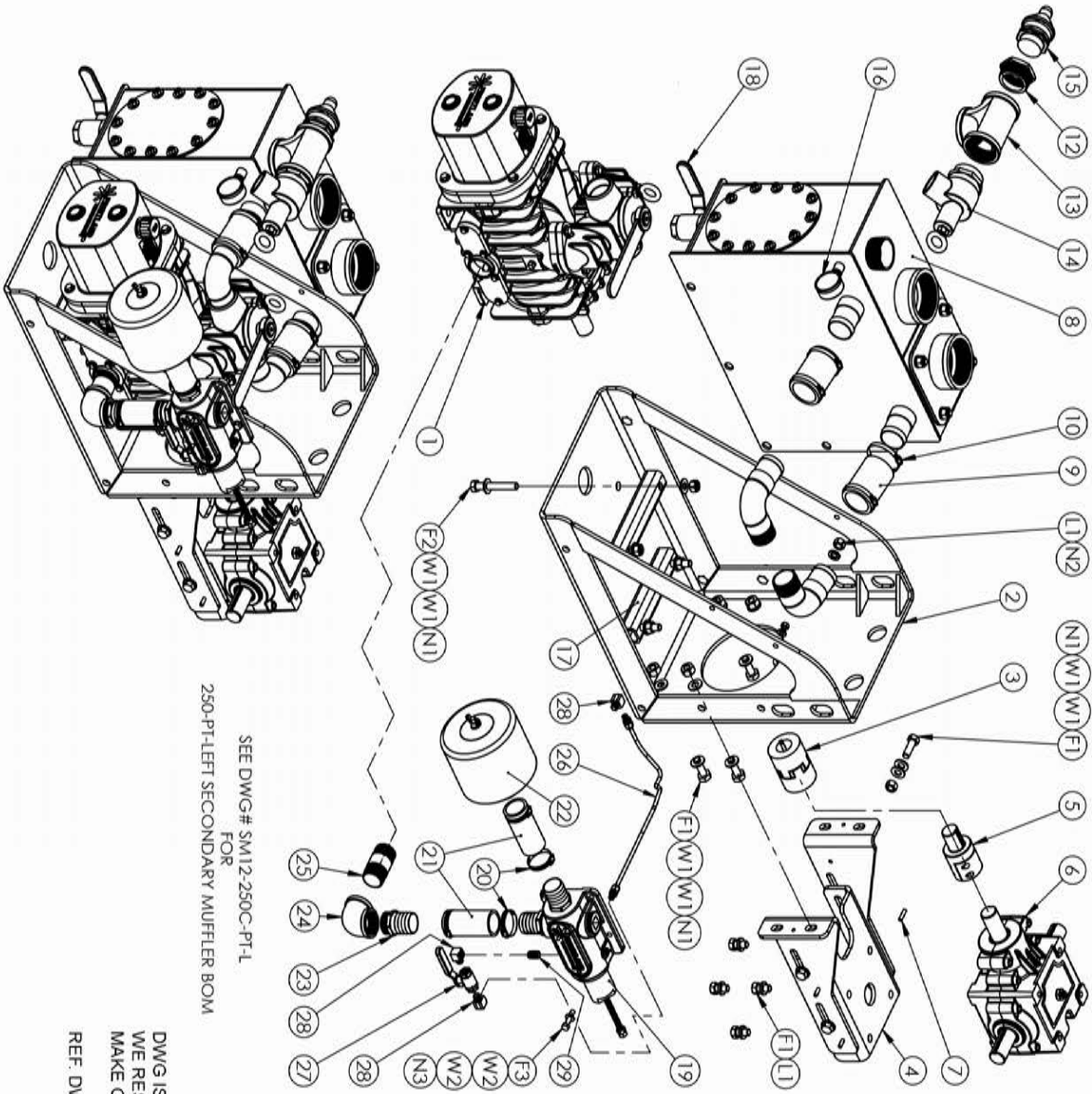

SEE DWG# SM12-250C-PT-1
FOR
250-PT-LEFT SECONDARY MUFFLER BOM

DWG IS FOR REFERENCE ONLY
WE RESERVE THE RIGHTS TO
MAKE CHANGES
REF. DWG# ELIM A-SMF344RL



ELIM A-SMF344RL Parts List

ITEM#	PART #	DESCRIPTION	QTY
1	344RU	RCF344 VACUUM PUMP	1
2	PF18-PT-L	344-PT PEDASTAL FRAME-LEFT	1
3	F100-A	F100 COMPLETE COUPLING WITH BUNA INSERT BORES: 1.25 X 1.25 PUMP AND GB	1
4	ADM18	344-PT ANGLE DRIVE MOUNT	1
5	RF250-SA	1-1/2" DIA. SHAFT EXTENSION ADAPTOR (USED WITH 11" AND 12" SHAFT DISTANCE ON GEAR-	1
6	RF500-GB400	RIGHT ANGLE GEAR BOX	1
7	1/4" X 1" LG SPLIT PIN	1/4" X 1" SPLIT PIN	6
8	SM12-250C-PT-L	250-PT-LEFT SECONDARY MUFFLER ASSM	1
9	2" HOSE	Ø2" RUBBER HOSE 4" LG.	2
10	2" HOSECLAMP	CLAMPS FOR RUBBER HOSE (M10 64-67mm)	4
11	FA250C	DIVERTER ELBOW DWG# SM12-FA	2
12	RF250-75A	2" MALE X 1.5" FEMALE, HEX BUSHING	1
13	RF250-76A	2" NPT TEE	1
14	2" PRV	PRESSURE RELIEF VALVE 2" NPT	1
15	VB	VACUUM RELIEF VALVE 1-1/2" NPT	1
16	PVG-2.5	PRESSURE VACUUM GAGE	1
17	Elim A344-PT-SB-T	SPACER TUBE FOR HOUSING (ELIM A344-PT)	2
18	M09-A-07	1" NPT BALL VALVE	2
19	RF870-AI	AIR INJECTION VALVE ASSEMBLY	1
20	1.5"HOSE CLIP	1.5" HOSE CLAMP (M8 52-55mm)	4
21	1.5" HOSE EXFL	1.5" HOSE GOODYEAR EXTREMEFLEX, 3" LG.	2
22	AI-870-F-NPT	AIR INJECTION FILTER FOR 344 PUMP WITH NIP- PLE 1-1/4 NPT	1
23	1.25"NPT-1.5BRB	1.25" NPT - 1.5" HOSE BARB FITTING	1
24	AI-870-5A	ELBOW 90 DEG. 1.25" NPT (FEMALE X FEMALE)	1
25		NIPPLE 1-1/4" NPT 2.5" LG.	1

ELIM A-SMF344RL Parts List Continued

ITEM#	PART #	DESCRIPTION	QTY
26	AI-870-83	SS BRAIDED HOSE 1/4" NPT 14" LONG	1
27	DBV31-B	1/4" BALL VALVE	1
28	RF250-32A	90 DEG. BRASS ELBOW 1/4" NPT MF (STREET ELB.)	3
29	A270-5	NIPPLE 1/4" NPT 7/8" LG.	1
F1	1/2" X 1-1/2"	1/2" NC 1.5" LONG ZINC PLATED HEX HEAD BOLTS	12
F2	1/2" X 3-1/2"	1/2" NC 3.5" LONG ZINC PLATED HEX HEAD BOLTS	4
F3		5/16" NC 1-1/2" LONG ZINC PLATED HEX HEAD BOLTS	2
W1	1/2" FLAT WASH-ER	1/2" Z.P. FLAT WASHER	16
W2	5/16"-FW	5/16" Z.P. FLAT WASHER	4
L1	1/2" L/W	1/2" LOCK WASHERS ZINC PLATED	4
N1		1/2" NC NYLOCK HEX NUT	8
N2	1/2" NUTS	1/2" NC NUTS ZINC PLATED	4
N3	5/16" NYLOCK NUTS	5/16" NC NYLOCK HEX NUT	2

SERVICE NOTE

USE AUTHENTIC FRUITLAND PARTS ONLY!

If you have any questions, or require further information on installing, operating and or the maintenance of your vacuum pump contact:

1-800-663-9003 - info@fruitland-mfg.com - sales@fruitland-mfg.com

ELIM G-SMF344L

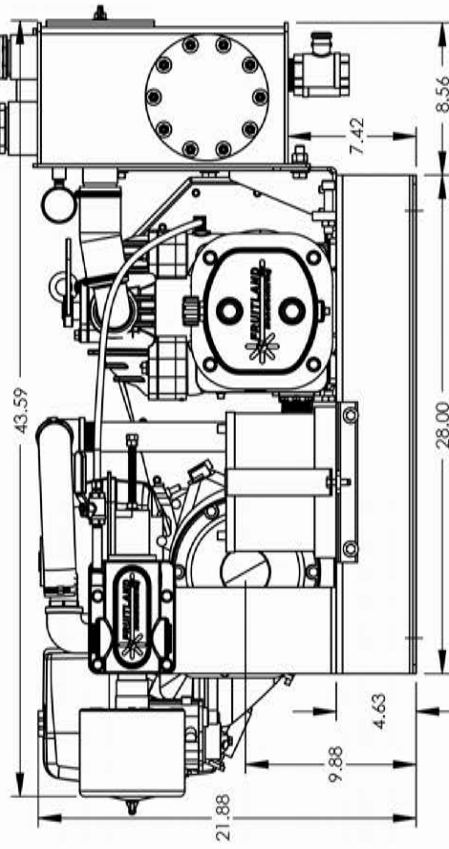
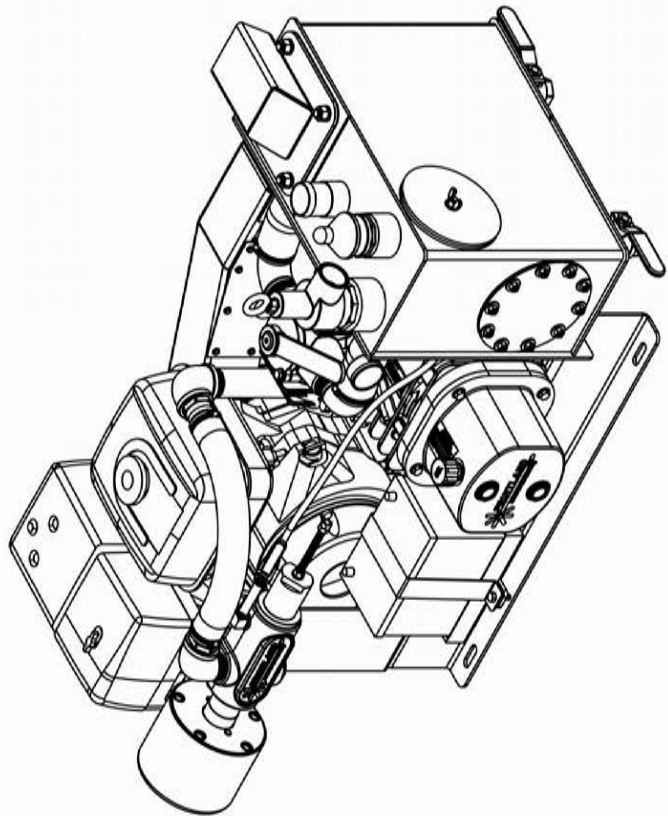
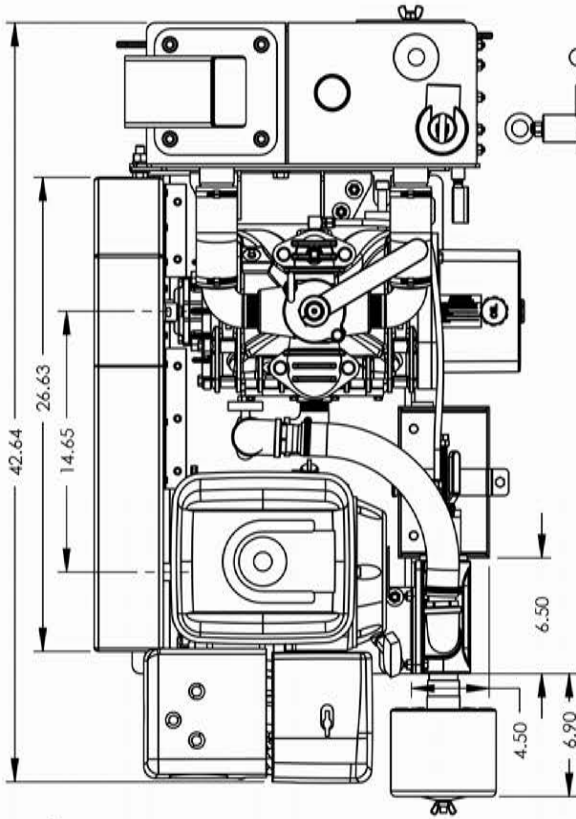
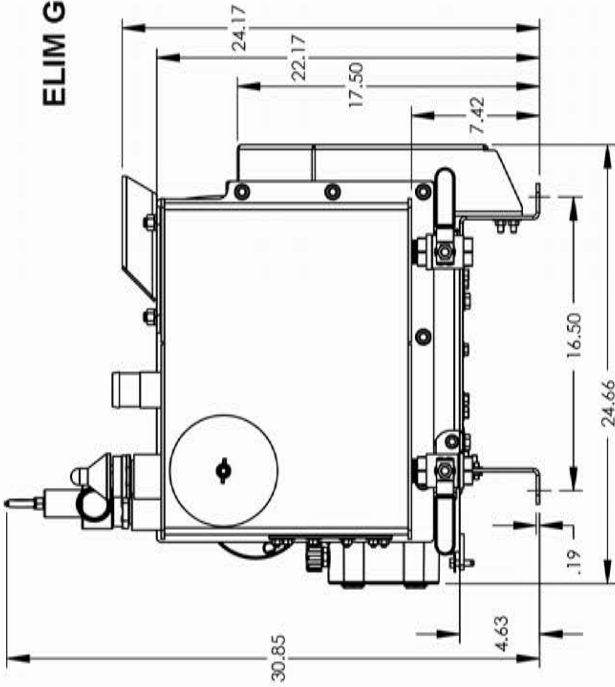

DWG IS FOR REFERENCE ONLY
WE RESERVE THE RIGHTS TO
MAKE CHANGES

REF: DWG# ELIM G-SMF344L-DIMS



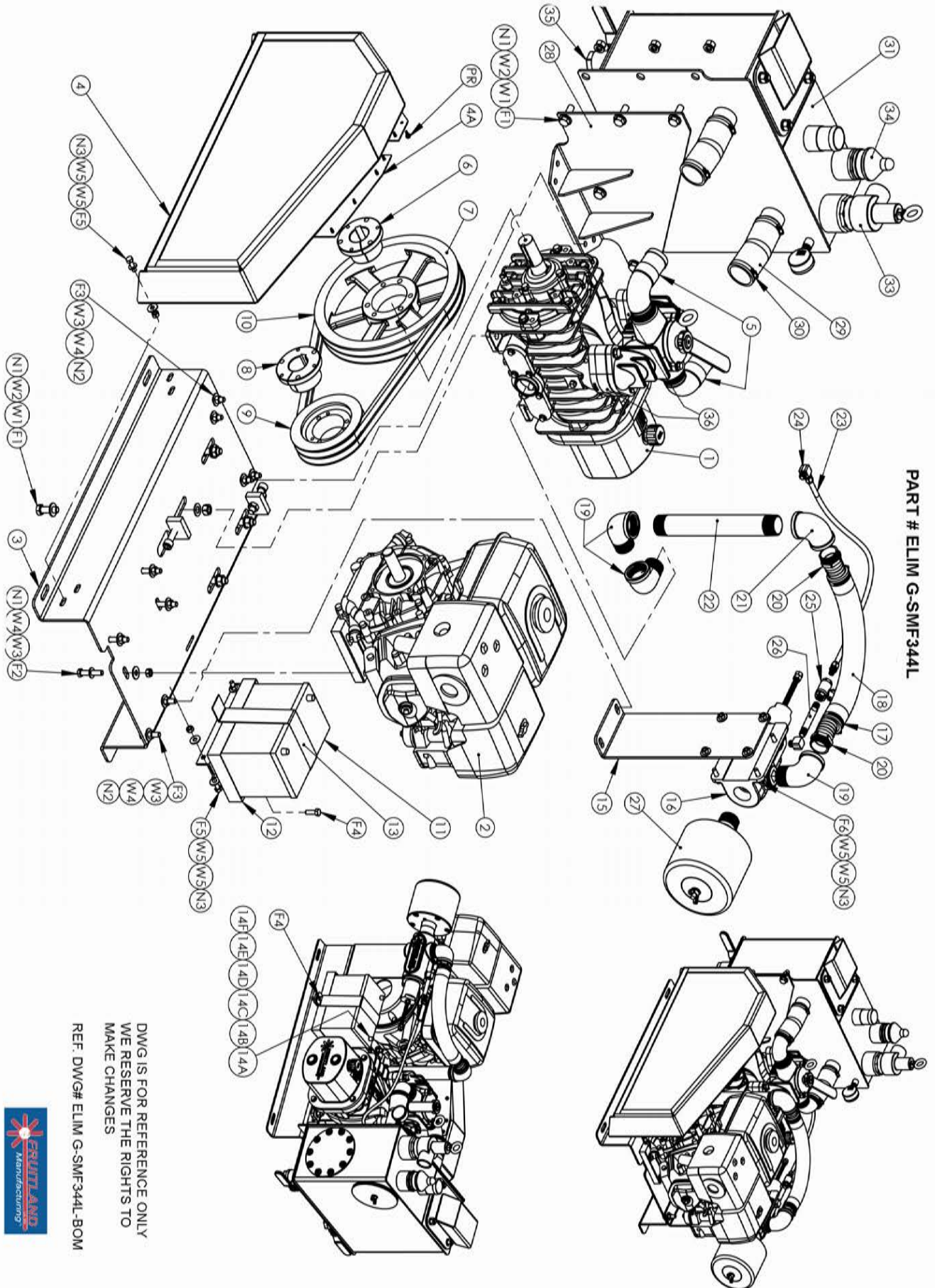

PART # ELIM G-SMF344L

DWG IS FOR REFERENCE ONLY
 WE RESERVE THE RIGHTS TO
 MAKE CHANGES
 REF: DWG# ELIM G-SMF344L-BOM



ELIM G-SMF344L Parts List

ITEM#	PART #	DESCRIPTION	QTY
1	344R	RCF344 VACUUM PUMP	1
2	FX420	FRUITLAND FX420 WITH ELECTRIC START	1
3	ELIM-G344-01	ELIM G344 BASE FRAME ASSEMBLY	1
4	ELIM-G250-02	ELIM G250 BELT GUARD	1
4A	ELIM G344-024	G344 BELT GUARD WIRE MESH	1
5	FA250C	DIVERTER ELBOW	2
6	SF1.25	SK BUSHING FOR 1.25" SHAFT. 1/4" KEY	1
7	2B12.4L	SHEAVE 12.4 SF 2 GROOVE B SECT.	1
8	SK1.0	SK BUSHING FOR 1" SHAFT. 1/4" KEY	1
9	2B6.0	6" SHEAVE 2 GROOVE B SECT.	1
10	ELIM-G250-03	B57 V-BELT	2
11	ELIM-G250-04	BATTERY	1
12	ELIM-G250-06	BATTERY FRAME	1
13	ELIM-G250-041	BATTERY HOLD DOWN CLAMP	1
14A	ELIM-G250-042	8 GA BATTERY WIRE BLACK, 16" LG.	1
14B	ELIM-G250-043	8 GA BATTERY WIRE RED, 14" LG.	1
14C	ELIM-G250-044	8 GA COPPER EYELET	2
14D	ELIM-G250-045	BATTERY TERMINAL BOOT BLACK	1
14E	ELIM-G250-046	BATTERY TERMINAL BOOT RED	1
14F	ELIM-G250-047	STARTER SOLENOID TERMINAL BOOT RED	1
15	ELIM G344-03	ELIM G344 BRACKET FOR AI	1
16	RF870-AI	AIR INJECTION VALVE ASSEMBLY	1
17	1.5"HOSE CLIP	1.5" HOSE CLAMP (M8 48-51mm)	2
18	1.5" HOSE EXFL	1.5" HOSE GOODYEAR EXTREMEFLEX, 12-1/2" LG.	1
19	RF870-71A	90 DEG. ELBOW 1-1/2" NPT MF (STREET ELBOW)	3
20	1.25"NPT-1.5BRB	1.25" NPT - 1.5" HOSE BARB FITTING	1
21	AI-870-5A	90 DEG. ELBOW 1.25" NPT (FIMALE X FIMALE)	1
22	1-1/4"-NIPPLE	NIPPLE 1-1/4" NPT 10.5" LG.	1
23	AI-870-83	SS BRAIDED HOSE 1/4" NPT 14" LONG	1

ELIM G-SMF344L Parts List Continued

ITEM#	PART #	DESCRIPTION	QTY
24	RF250-32A	90 DEG. BRASS ELBOW 1/4" NPT MF (STREET ELB.)	3
25	DBV31-B	1/4" BALL VALVE	1
26	RF250-30A	NIPPLE 1/4" NPT 3-1/2" LG.	1
27	AI-870-F	AIR INJECTION FILTER WITH NIPPLE 1-1/4" NPT	1
28	ELIM G344-04	ELIM G344 MUFFLER BRACKET	1
29	2" HOSE	Ø2" RUBBER HOSE 5.5" LG.	2
30	2" HOSECLAMP	CLAMPS FOR RUBBER HOSE (M10 64-67mm)	4
31	SM20-344	344 SECONDARY MUFFLER ASSM	1
32	PVG-2.5	PRESSURE VACUUM GAGE	1
33	PRV-2"	PRESSURE RELIEF VALVE 2" NPT	1
34	VB	VACUUM RELIEF VALVE 1-1/2" NPT	1
35	M09-A-07	1" NPT BALL VALVE	2
36	250-DSF-IN	250 DIVERTER SPACER FLANGES (1" THICK)-INTAKE	1
37	250-DSF-EX	250 DIVERTER SPACER FLANGES (1" THICK)-EXHAUST	
F1	1/2" X 1-1/2" HEX HEAD	1/2" NC 1-1/2" LONG ZINC PLATED HEX HEAD BOLTS	9
W1	1/2" F/W-USS	1/2" ZINC PLATED FLAT WASHERS, LARGE	9
W2	1/2" F/W-SAE	1/2" ZINC PLATED FLAT WASHERS, SMALL	9
N1	1/2" NYLOCK NUTS	1/2" NC NYLOCK HEX NUT	9
F2	3/8" X 2"	3/8" NC 2" LONG ZINC PLATED HEX HEAD BOLTS	4
F3	3/8" X 1-1/2"	3/8" NC 1-1/4" LONG ZINC PLATED HEX HEAD BOLTS	6
W3	3/8" F/W-USS	3/8" ZINC PLATED FLAT WASHERS, LARGE	10
W4	3/8" F/W-SAE	3/8" ZINC PLATED FLAT WASHERS, SMALL	10
N2	3/8" NYLOCK NUTS	3/8" NC NYLOCK HEX NUT	10
F4		5/16"NC 1" LONG FLAX FLANGE SERRATED BOLTS	1
F5	5/16"X1" HEX BOLT	5/16" NC 1" LONG ZINC PLATED HEX HEAD BOLTS	6
F6	5/16"X1-1/2" HEX BOLT	5/16" NC 1-1/2" LONG ZINC PLATED HEX HEAD BOLTS	4
W5	5/16"WASHER	5/16" ZINC PLATED FLAT WASHERS	20
N3	5/16" NYLOCK NUTS	5/16" NC NYLOCK HEX NUT	10
PR		ALUMINUM BLIND RIVET WITH BSTEEL MANDREL, LARGE- DIAMETER DOMED HEAD, 3/16" DIA., for 0.126"-0.25" MATERIAL THICKNESS	12

PART # ELIM H-SMF344RL

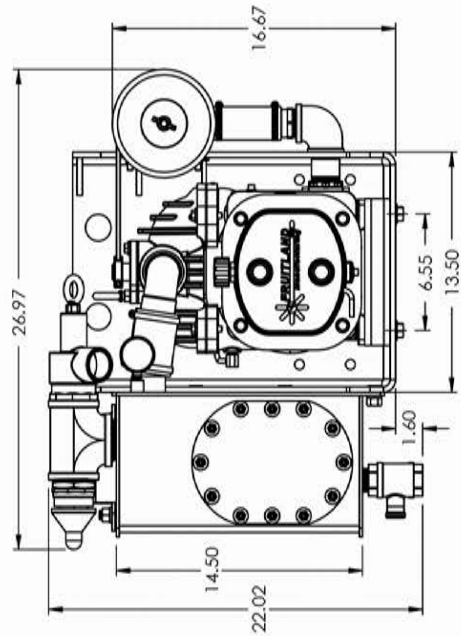
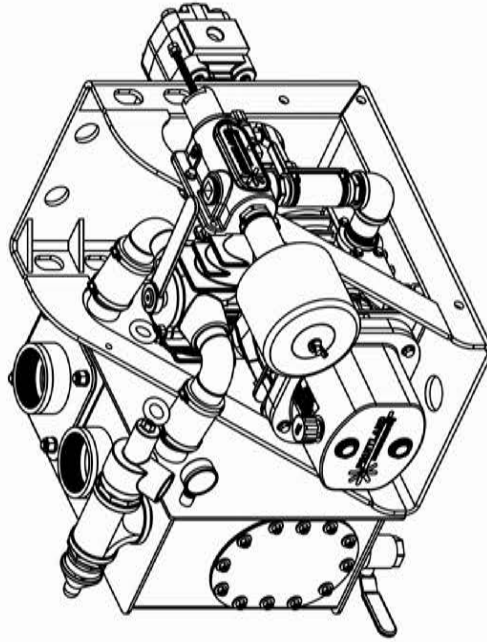
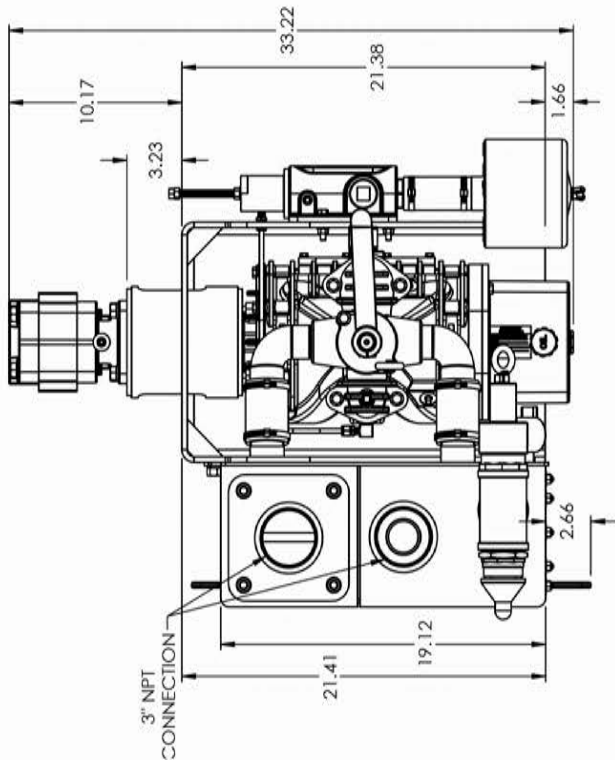
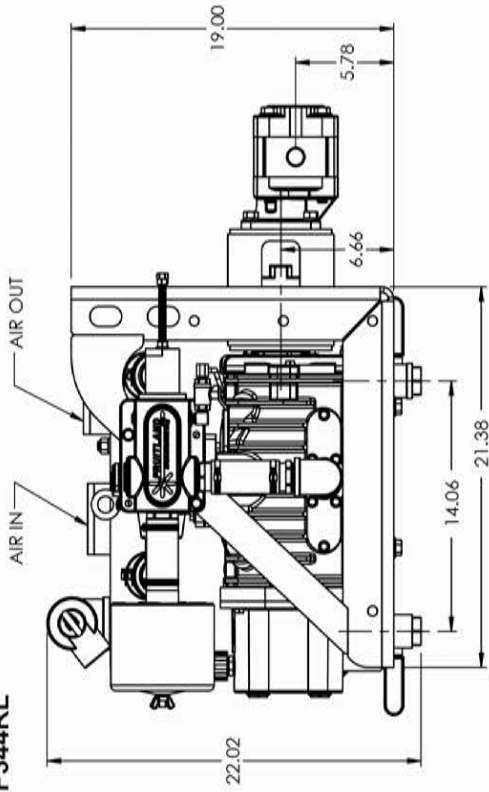

DWG IS FOR REFERENCE ONLY
WE RESERVE THE RIGHTS TO
MAKE CHANGES

REF. DWG# ELIM H-SMF344RL-DIMS



PART # ELIM H-SMF344RL

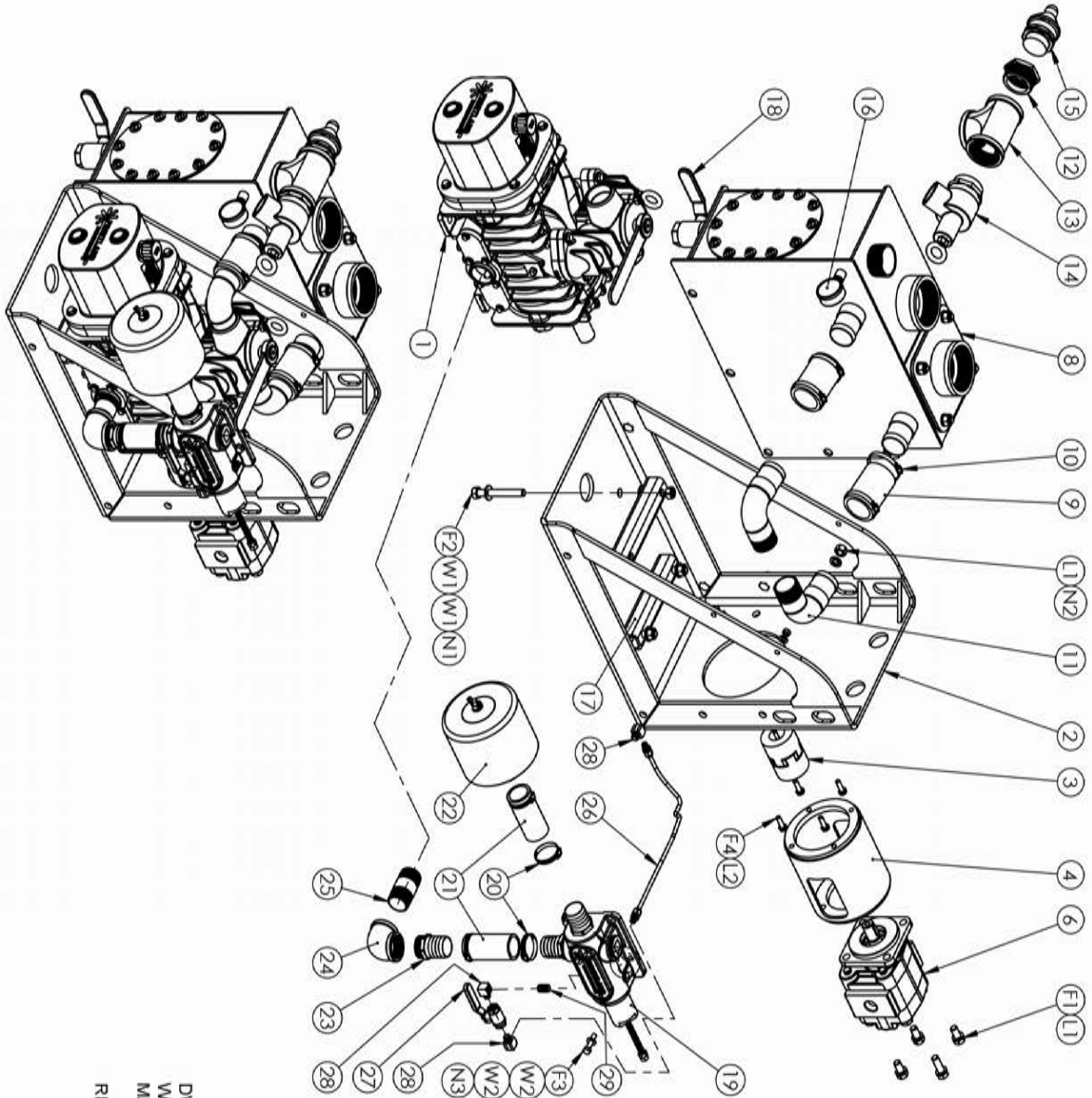

DWG IS FOR REFERENCE ONLY
 WE RESERVE THE RIGHTS TO
 MAKE CHANGES

REF. DWG# ELIM H-SMF344RL



ELIM H-SMF344RL Parts List

ITEM#	PART #	DESCRIPTION	QTY
1	344RU	RCF344 VACUUM PUMP	1
2	PF18-PT-L	344-PT PEDASTAL FRAME-LEFT	1
3	F100-H	F100 COMPLETE COUPLING WITH BUNA INSERT BORES: 1.25 X 0.875 PUMP AND HYD MOTOR	1
4	RF344-HMA	344-PT HYDRAULIC MOTOR ADAPTOR	1
6	P250-HM	HYDRAULIC MOTOR	1
8	SM12-250C-PT-L	250-PT-LEFT SECONDARY MUFFLER ASSM	1
9	2" HOSE	Ø2" RUBBER HOSE, 4" LG.	2
10	2" HOSECLAMP	CLAMPS FOR RUBBER HOSE (M10 64-67mm)	4
11	FA250C	DIVERTER ELBOW DWG# SM12-FA	2
12	RF250-75A	2" MALE X 1.5" FIMALE, HEX BUSHING	1
13	RF250-76A	2" NPT TEE	1
14	2" PRV	PRESSURE RELIEF VALVE 2" NPT	1
15	VB	VACUUM RELIEF VALVE 1-1/2" NPT	1
16	PVG-2.5	PRESSURE VACUUM GAGE	1
17	Elim A344-PT-SB-T	SPACER TUBE FOR HOUSING (ELIM A344-PT)	2
18	M09-A-07	1" NPT BALL VALVE	2
19	RF870-AI	AIR INJECTION VALVE ASSEMBLY	1
20	1.5"HOSE CLIP	1.5" HOSE CLAMP (M8 52-55mm)	4
21	1.5" HOSE EXFL	1.5" HOSE GOODYEAR EXTREMEFLEX, 3" LG.	2
22	AI-870-F-NPT	AIR INJECTION FILTER FOR 344 PUMP WITH NIP- PLE 1-1/4 NPT	1
23	1.25"NPT-1.5BRB	1.25" NPT - 1.5" HOSE BARB FITTING	1
24	AI-870-5A	ELBOW 90 DEG. 1.25" NPT (FIMALE X FIMALE)	3
17	1.5"HOSE CLIP	1.5" HOSE CLAMP (M8 48-51mm)	2
18	1.5" HOSE EXFL	1.5" HOSE GOODYEAR EXTREMEFLEX, 12-1/2" LG.	1
19	RF870-71A	90 DEG. ELBOW 1-1/2" NPT MF (STREET ELBOW)	3
20	1.25"NPT-1.5BRB	1.25" NPT - 1.5" HOSE BARB FITTING	1
21	AI-870-5A	90 DEG. ELBOW 1.25" NPT (FIMALE X FIMALE)	1
22	1-1/4"-NIPPLE	NIPPLE 1-1/4" NPT 10.5" LG.	1

ELIM H-SMF344RL Parts List Continued

ITEM#	PART #	DESCRIPTION	QTY
23	1.25"NPT-1.5BRB	1.25" NPT - 1.5" HOSE BARB FITTING	1
24	AI-870-5A	ELBOW 90 DEG. 1.25" NPT (FEMALE X FEMALE)	3
25		NIPPLE 1-1/4" NPT 2-1/2" LG.	1
26	AI-870-83	SS BRAIDED HOSE 1/4" NPT 14" LONG	1
27	DBV31-B	1/4" BALL VALVE	1
28	RF250-32A	90 DEG BRASS ELBOW 1/4" NPT MF (STREET ELB.)	3
29	A270-5	NIPPLE 1/4" NPT 7/8" LG.	1
F1	1/2" X 1"	1/2" NC 1" LONG ZINC PLATED HEX HEAD BOLTS	4
F2	1/2" X 3.5"	1/2" NC 3.5" LONG ZINC PLATED HEX HEAD BOLTS	4
F3		5/16" NC 1-1/2" LONG ZINC PLATED HEX HEAD BOLTS	2
F4	RF500-48A	HEX BOLT M8x25	4
W1	1/2" FLAT WASHER	1/2" Z.P. FLAT WASHER	8
W2	5/16"-FW	5/16" Z.P. FLAT WASHER	4
L1	1/2" L/W	1/2" LOCKWASHERS ZINC PLATED	8
L2	RF120-96A	LOCK WASHER M8	4
N1		1/2" NC NYLOCK NUT	4
N2	1/2"NUTS	1/2" NC NUTS ZINC PLATED	4
N3	5/16" NYLOCK NUTS	5/16" NC NYLOCK NUT	2

Truck Mounting Instructions for Eliminator System with Angle Drive

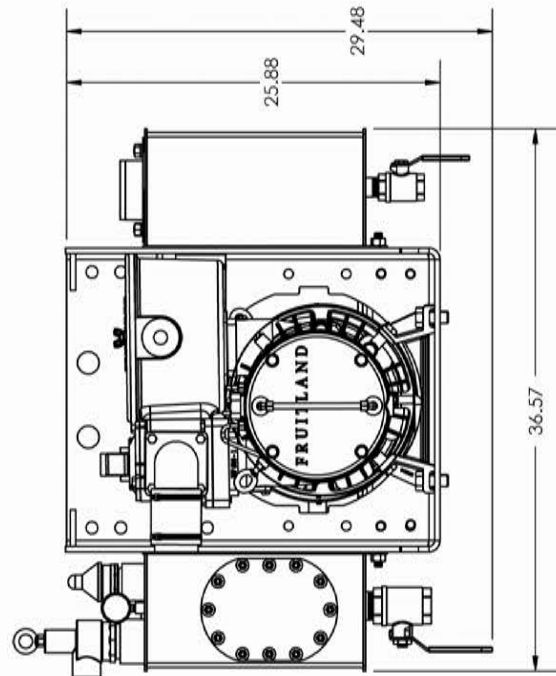
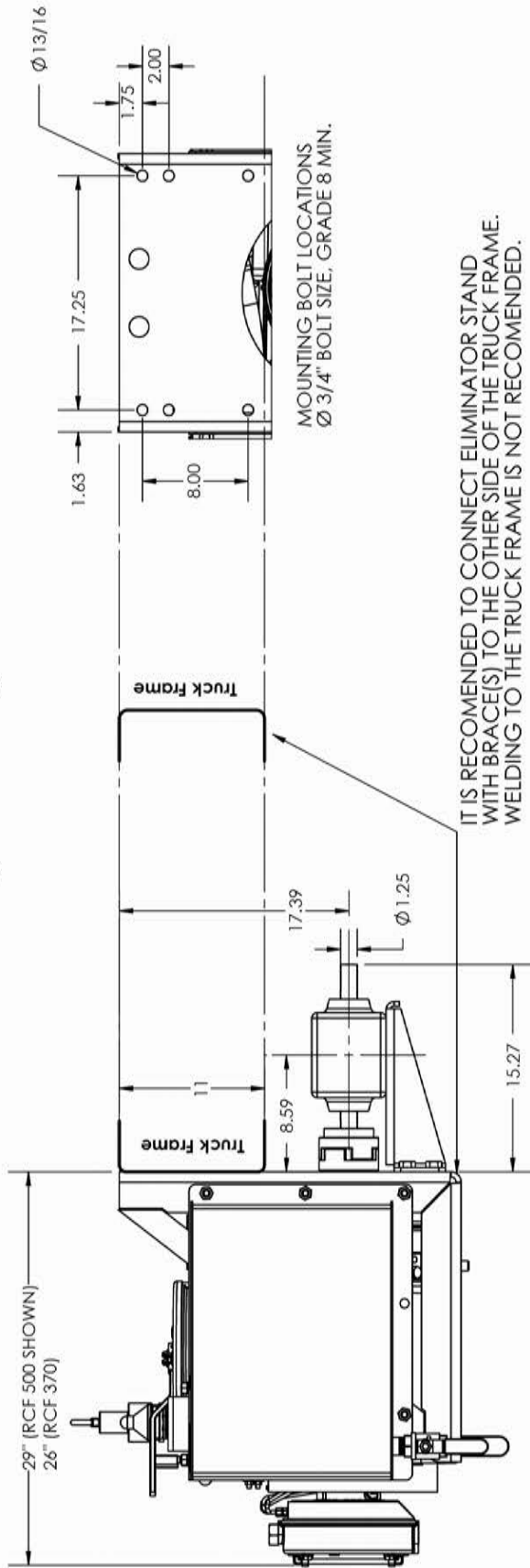

DWG IS FOR REFERENCE ONLY
 WE RESERVE THE RIGHTS TO
 MAKE CHANGES

REF. DWG# ELIM G344-DIMS



PUMP WARRANTY

1. **WARRANTY POLICY — WHAT WE COVER:** Subject to the terms of this warranty (the “WARRANTY”), vacuum pumps (the “PRODUCT”) manufactured by R.T. Hamilton and Associates Ltd. (FRUITLAND MANUFACTURING) are warranted to be free from defects in material and workmanship for a maximum period of two (2) years from the date of shipment to Buyer. THIS IS THE SOLE AND EXCLUSIVE PRODUCT WARRANTY GIVEN BY FRUITLAND MANUFACTURING TO BUYER AND IS IN LIEU OF, AND EXCLUDES, ALL OTHER WARRANTIES, EXPRESS OR IMPLIED, ARISING BY OPERATION OF LAW OR OTHERWISE, INCLUDING, BUT NOT LIMITED TO, ANY IMPLIED WARRANTIES OF MERCHANTABILITY OR FITNESS FOR A PARTICULAR PURPOSE. COMPONENTS WHICH MAY BE SUPPLIED AS PART OF AN ASSEMBLY, OR SPARE PART(S), AND NOT MANUFACTURED BY FRUITLAND MAUFACTURING ARE LIMITED ONLY TO THE WARRANTY EXTENDED BY THE MANUFACTURER(S) OF THE COMPONENT(S).
2. **WARRANTY CLAIMS — HOW WE RESPOND TO WARRANTY ISSUES:** In the event of a defect in a PRODUCT covered by this WARRANTY, FRUITLAND MANUFACTURING shall repair or replace the affected PRODUCT, or components of the affected PRODUCT, at its sole discretion. This is the BUYER'S sole and exclusive remedy. BUYER shall comply with FRUITLAND MANUFACTURING's WARRANTY Claims Process in order to enforce this WARRANTY.
3. **WARRANTY EXCLUSIONS — THINGS THAT WILL RESULT IN LOSS OF WARRANTY COVERAGE OR WHICH ARE NOT COVERED:**
 - a. This WARRANTY shall be void if:
 - i. BUYER fails to maintain the PRODUCT through proper care and maintenance procedures;
 - ii. BUYER fails to operate and/or use the PRODUCT in the manner in which it was intended, and in accordance with the PRODUCT manual(s), or otherwise misuses or abuses the PRODUCT;
 - iii. BUYER fails to notify FRUITLAND MANUFACTURING of a PRODUCT defect covered under this WARRANTY within 72 hours of discovery of the defect, or fails to cooperate with FRUITLAND MANUFACTURING in investigating the PRODUCT defect;
 - iv. Personnel who have not been approved by FRUITLAND MANUFACTURING make repairs or modifications to the PRODUCT;
 - v. Replacement parts that have not been approved by FRUITLAND MANUFACTURING are used in the PRODUCT; or
 - vi. BUYER fails to pay for the PRODUCT in full.
 - b. Damage to the PRODUCT arising from extreme weather conditions or affixing equipment or materials to the PRODUCT that have not been approved by FRUITLAND MANUFACTURING, is not covered by this WARRANTY. LIMITATION OF DAMAGES: FRUITLAND MANUFACTURING SHALL HAVE NO LIABILITY TO BUYER OR OTHERWISE ARISING FROM, OR IN ANY WAY CONNECTED TO, THE PRODUCT, INCLUDING ITS SALE, USE OR OPERATION, EXCEPT AS EXPRESSLY SET OUT HEREIN. IN NO EVENT SHALL FRUITLAND MANUFACTURING BE LIABLE FOR LOST PROFITS OR FOR SPECIAL, CONSEQUENTIAL, EXEMPLARY OR INCIDENTAL DAMAGES OF ANY KIND WHETHER ARISING IN, CONTRACT, TORT, PRODUCT LIABILITY, NEGLIGENCE, STRICT LIABILITY OR OTHERWISE, EVEN IF FRUITLAND MANUFACTURING WAS ADVISED OF THE POSSIBILITY OF SUCH LOST PROFITS OR DAMAGES. IN NO EVENT SHALL FRUITLAND MANUFACTURING BE LIABLE TO BUYER FOR ANY DAMAGES WHATSOEVER IN EXCESS OF THE TOTAL PRICE PAID BY BUYER FOR THE PRODUCT. BUYER HEREBY WAIVES ANY CLAIM THAT THE EXCLUSIONS OR LIMITATIONS IDENTIFIED HEREIN DEPRIVE IT OF AN ADEQUATE REMEDY OR CAUSE THIS OR ANY OTHER AGREEMENT WITH FRUITLAND MANUFACTURING TO FAIL OF ITS ESSENTIAL PURPOSE.



NOTICE - WARRANTY CLAIM

In the event of pump failure while the pump is still under warranty, pumps are to be returned to factory without dismantling or other alterations for warranty assessment. Violation of this condition will void warranty. All shipping costs are the customer's responsibility.

Model Number

Thank you for purchasing a Fruitland Rotary Vane Vacuum Pump. Our quality control program has been developed to ensure this vacuum pump and its components are free from defects in materials and workmanship. With proper maintenance and operation your Fruitland pump should give many years of trouble free use.

Please read the owner's manual completely before operating your new Fruitland pump.

SERVICE NOTE

USE AUTHENTIC FRUITLAND PARTS ONLY!

If you have any questions, or require further information on installing, operating and or the maintenance of your vacuum pump contact:

1-800-663-9003 - info@fruitland-mfg.com - sales@fruitland-mfg.com

This is the Serial Number of your Pump:

Preface

This Manual is given with your pump to help operators and owners understand the working and maintenance of your newly acquired unit.

Please familiarize yourself and any operator with the contents of this booklet. Keep a record of the serial number handy, in case you need any parts or information in the future.

We at Fruitland are committed to quality, reliability, and guaranteed performance.

Purchased From: (Dealer's Stamp)

Date:

.....

MM / DD / YY

Notes



291_17_Q



**Attention: Read owner's manual fully before operating pump.
Failure to do so can result in personal injury, severe pump damage and may
void warranty.**

Fruitland Manufacturing
324 Leaside Ave, Stoney Creek Ontario. Canada L8E 2N7
905-662-6552 • Toll Free: 1-800-663-9003
www.fruitlandmanufacturing.com